

# **Bruce Bartley Family Trust**

36 Locheagles Rise, Kinloch, Taupō

Earthworks Management Plan

220069\_Rev.1  
8 June 2023

## Bruce Bartley Family Trust

36 Locheagles Rise, Kinloch, Taupō

Earthworks Management Plan

**Prepared by:**



---

Lourdes Uriarte  
Civil Engineer  
BEng Tech (Civil)

**Reviewed and Approved  
for Release by:**



---

Sunil Prasad  
Engineering Manager  
Dip (Civil), Adv. Dip (Civil), BE (Hons) Civil, MEngNZ

**Date:** 8 June 2023  
**Reference:** 220069  
**Status:** Final  
**Revision:** 1  
**Previous Revision Date:** 1 November 2022

This document is the property of Cheal Consultants Limited. Any unauthorised employment or reproduction, in full or part is forbidden.

This document has been prepared for a specific purpose for the above client and shall not be used for any other unauthorised purpose. Cheal Consultants Limited does not acknowledge any duty of care or responsibility to any other party.

© Cheal Consultants Limited

## TABLE OF CONTENTS

<b>1.</b>	<b>INTRODUCTION .....</b>	<b>5</b>
	1.1. Proposed Activity .....	5
	1.2. General.....	5
<b>2.</b>	<b>EROSION AND SEDIMENT CONTROL .....</b>	<b>7</b>
	2.1. Monitoring and Maintenance .....	7
	2.2. Erosion Control .....	7
	2.2.1 Clean Water Diversion Bund .....	7
	2.2.2 Dirty Water Diversion Bund .....	7
	2.2.3 Contour (Cut-Off) Drain .....	8
	2.2.4 Stabilised Construction Entrance .....	8
	2.2.5 Stabilisation - Topsoil, Grass Seeding and Straw Mulch .....	8
	2.3. Sediment Control .....	8
	2.3.1. Decanting Earth Bunds (DEB) .....	9
	2.3.2. Stormwater Inlet Protection .....	9
	2.3.3. Flocculation Management Plan .....	9
<b>3.</b>	<b>SEDIMENT CONTROL AS-BUILTS .....</b>	<b>9</b>
<b>4.</b>	<b>DUST CONTROL.....</b>	<b>10</b>
<b>5.</b>	<b>CONSTRUCTION TIMETABLE .....</b>	<b>10</b>
	5.1. Construction Signs .....	10
	5.2. Site Access .....	11
	5.3. Hours of Work .....	11
	5.4. Contractor Programme of Works .....	11
<b>6.</b>	<b>MAINTENANCE, MONITORING AND REPORTING PROCEDURES.....</b>	<b>11</b>
<b>7.</b>	<b>ARCHAEOLOGICAL DISCOVERIES .....</b>	<b>12</b>
<b>8.</b>	<b>REVIEW PROCEDURES.....</b>	<b>13</b>
<b>9.</b>	<b>CONTACT DETAILS.....</b>	<b>13</b>

**Appendices -**

1. Cheal Topographical Site Survey 16666-TP01 and Asbuilt plan 2013 -104-AB205
2. VERTICAL ARTS Architectural Plans Set # 1718 Bartley Residency L1 – The Eagles, Locheagles Rise, Kinloch Plans A0.0; SD1.1 to SD3.11
3. VERTICAL ARTS Earthworks Plan RC2.0; Proposed Final Contour Levels; Building Section Plans RC4.0 and RC4.1
4. Cheal Erosion and Sediment Control Sketch 220069-SK001 to SK004; Cheal Standard Drawings CH-201 Earthworks Sediment & Erosion Diversion Bund Details; CH-202 - Earthworks Lot Runoff Sediment Control Details
5. Relevant Sections from WRC Guidelines and Floc Socks
6. Sediment Control As-built Templates
7. Contractors Programme of Works (to be submitted by Principal).

# 1. INTRODUCTION

## 1.1. Proposed Activity

This Earthworks Management Plan (EMP) is for the construction and general earthworks for a large dwelling involving earthworks above 1.5m cut and fill.

This existing lot, 36 Locheagles Rise, was part of the Locheagles Subdivision Stage 3A completed in 2013 and labelled as Lot 1. As part of the subdivision works, earthworks were carried out on this lot. A topographical site survey was carried out on 30.03.2020 for the purpose of developing this New Dwelling, refer 16666-TP01. On cross check examination, the topographical survey data presents no modification between subdivision survey 2013 and site survey of 2020, no further earthworks have occurred on site since subdivision stage.

The proposed development consists of the following:

- Main level 750 m<sup>2</sup>
- Second Level 358 m<sup>2</sup>
- Bothy 177m<sup>2</sup>
- Garage 171 m<sup>2</sup>

Refer to Vertical Arts Plans Set Bartley Residence#1718 dated 19.10.2021 in Appendix 2.

The development will be completed in one stage. The retaining wall to accommodate the earthworks will be part of the structural and construction works.

The property sits at the end of a private road. Written approvals by private properties have been sought for this development.

The earthworks are to commence as soon as this Earthworks Management Plan is approved, Consents are granted, and the contractor is available to start on site (anticipated to be early April 2023). It is anticipated that the proposed development construction works, including earthworks, will take approximately 3 years with an allowance for inclement weather.

Erosion and sediment controls will be required for the works. The following report identifies the controls to be implemented and the attached drawings indicate the locations of these controls.

All erosion and sediment controls will remain in place until all disturbed areas have been stabilised.

## 1.2. General

This EMP shall be implemented throughout the construction period with all associated aspects of the construction until all areas are stabilised.

The existing ground levels follow a northeast direction towards Locheagles Rise.

This property is located at the end of Locheagles Rise and shares a boundary with the upper side of Lots 3 & 4 which is a green embankment area covered with vegetation. As shown on 16666-TP001 - Topographic Survey of Lot 1 DP 474891 and Part of Lot 3 and 4 DP474891I plan, a building platform was created on this property as part of the Locheagles subdivision Stage 3.

As shown on the Earthworks Cut to Fill Plans in Appendix 3 the site requires to be extensively earthworked.

Earthwork volumes are approximately 8,700m<sup>3</sup> of cut, with a fill volume of 1,100m<sup>3</sup>. The maximum depths of cut and fill are expected to be around 7.00m cut and 1.50m fill for the building platform, and 5m fill for the depression.

The excess cut volume of approximately 4100m<sup>3</sup> will be relocated on site. The proposed location of the excess fill is shown on Sketch 220069- SK02. The upper area of the embankment, where a step drop area is located, will be filled to extend the building lawn areas as shown on Cross Section A – A. The depression will be filled to follow the surrounding embankment profile areas as shown on Cross Section B – B on 220069-SK03. The depression area is part of Lot 3, above the right of way, which the applicant has obtained approval from the owner of Lot 3 to relocate the excess cut material to the embankment area in order to obtain a balance cut to fill on-site. Lot 4 doesn't have earthworks and will remain stabilised.

The new formed embankment area will then be planted to form a natural undulating embankment. The embankment area is approximately 2200m<sup>2</sup>. The maximum slope of the embankment will be kept below 1:4 following the existing embankment slope. As the embankment is outside of the specified building platforms identified by the consent notice on the title it is unable to be built on.

Earthworks for the embankment will require overfill and cut back to ensure the new material is "keyed" into the existing material and trimmed back to form the slope required.

The temporary works will be controlled by DEBs. Four DEBs, each with a total volume of 90m<sup>3</sup> each, are proposed to contain the whole construction site including the area of the embankment, as shown on 220069-SK-001.

Methodology to manage Erosion and Sediment Control:

1. Install dirty water and clean water bunds to enable works for access road. Stabilise entrance to the site.
2. Boundaries with the Right of Way will be bunded off or a silt fence to be used. Bunds to have a setback of 1.5m to contain all runoff on site.
3. Clean Water Bunds along southwest boundary with Lot 6 and prevent clean water entering the earthworks area.
4. DEB 1 & 2 located on the higher platform will be fitted with a Novocoil outlet drain extended to the lower area to prevent erosion on embankment.
5. DEBs in the lower area will capture all runoff from earthworks on the embankment area. The dirty bunds direct all runoff to these DEB controls. All DEBs to be lined with a geotextile fabric to allow removal of sediment at the end of the works. DEBs shall be maximum 1m depth.
6. Stormwater inlet protection to be installed in two cesspits on the Right of Way below this development.
7. At the southeast boundary a clean water diversion bund will be installed to prevent clean water entering the site; along the rest of the boundaries contour bunds and cut off drains will be installed as necessary to direct runoff to a control device.

8. Install a drivable bund to allow construction traffic access to the area and prevent dirty water from exiting the site area while works are carried out. Bunds can be removed during the day to allow works but shall be reinstated every night.
9. As works progress to form the building platform, hardstand areas will be covered with metal to avoid dust on windy days and to prevent erosion when raining. As the platform is formed a metallised perimeter bund will be placed to prevent water running away from the area. A pit with a Novocoil overflow pipe will be placed into the lower area. . At this time the runoff for this area will be clean water and it will be discharged into stabilised area part of Lot 4 &3 with stablish green cover
10. Earthworks will be carried out to allow the cut to be placed on site, minimising the formation of big stockpiles. Stockpiles will be bunded or silt fences will be installed around them to prevent water entering the area. Any stockpile on site shall be covered with geotextile to prevent dust as required.

When all bulk earthworks are completed and the gully area is filled and stabilised. Lots 3 &4 remained embankments will be planted and landscaped to recreate a natural undulating embankment. All controls shall be located in allowance for earthworks and services to be constructed.

All erosion and sediment controls will be constructed and maintained in general accordance with the document entitled 'Erosion and Sediment Control, Guidelines for Soil Disturbing Activities – Waikato Regional Council Technical Report No. 2009/02\*', together with the appropriate updated factsheets found on the WRC website (Guidelines), wherever possible.

Relevant portions of the Guidelines are attached in Appendix 5 for controls specified in this report.

## 2. EROSION AND SEDIMENT CONTROL

### 2.1. Monitoring and Maintenance

All erosion and sediment controls will be inspected on a weekly basis (minimum) by the site foreman during dry weather, as well as prior to and immediately following significant rainfall events.

All maintenance requirements identified during routine inspections of erosion and sediment controls will be implemented as soon as practicable and in any case prior to a significant rainfall event.

### 2.2. Erosion Control

#### 2.2.1 Clean Water Diversion Bund

As required, clean water diversion bunds shall be constructed as shown on the attached drawings and as per the Guidelines.

#### 2.2.2 Dirty Water Diversion Bund

A series of dirty water diversion bunds are to be installed around the perimeter of the site and within each stormwater catchment on the site to collect dirty water runoff from the earthworks activities

and direct it to the appropriate sediment controls. These bunds typically follow the lower edge of the earthworks boundary of each catchment as shown on the drawings.

The dirty water diversion bunds shall be constructed as per the Guidelines.

### **2.2.3 Contour (Cut-Off) Drain**

To allow some flexibility to the construction works stormwater contour (cut-off) drains shall be used to divert stormwater from the construction site across proposed road and access alignments during construction, to suit stormwater catchment boundaries. Whilst the cut-off drains may need to be removed for access during the construction day, they shall be re-instated prior to the site being left overnight.

### **2.2.4 Stabilised Construction Entrance**

Construction of the proposed development will be undertaken from within the site itself with construction traffic accessing the site via Locheagles Rise road. A stabilised construction area shall be installed to prevent sediment leaving the site or runoff exiting the site.

Prior to construction of the 'stabilised construction entrance', all services shall be identified on site to avoid damaging services. As-builts of the services are available on the TDC website and Cheal As-builts plans. Contractor to notify and identify if other services are encountered.

### **2.2.5 Stabilisation - Topsoil, Grass Seeding and Straw Mulch**

Following completion of earthworks, private roading will be sealed with permanent stormwater controls in place. The remainder of the site will be topsoiled, sown with grass seed (either traditional or hydrosol) and where necessary straw mulch shall be placed to provide immediate stabilisation of all exposed surfaces and batters. All controls shall remain in place until stabilisation occurs, and approval is granted from WRC to remove controls. Controls such as bunds and decant pits may be removed just prior to stabilisation, provided fine weather and stabilisation occurs immediately (same day) following removal of controls.

## **2.3. Sediment Control**

The site area is approximately 11,000 m<sup>2</sup>. To accommodate the different levels of the construction and to suit the property, all areas will be managed via DEBs. Four DEBs will be installed onsite. Three DEBs will be constructed on the higher platform to control 6000m<sup>2</sup> with a volume of 90m<sup>3</sup> each. At the lower level to ROW a DEB will provide control for the back area of the building and ROW. At the lower level 1 DEB 90m<sup>3</sup> will provide control for the fill on the embankment and to the remaining areas. A bund around the Right of Way will provide an extra layer of protection for sediment control.

The two existing cesspits on the right of way, just below this lot, will require stormwater inlet protection.

In the manner described below the risk of sediment laden water entering the environment is minimised.



### 2.3.1. Decanting Earth Bunds (DEB)

A DEB is required to allow for the construction works until the time the site is completed. The DEB will be part of the stormwater attenuation for this property. All DEB's will be lined with geofabric and sediment shall be cleared out from time to time as required. The geofabric will be removed at the end of the construction and upgraded to scoria pits to provide an additional line of storage for runoff from the embankment.

On the building platform, upper platform, where the area slope is less than 10 percent the DEB will be 20m<sup>3</sup> per 1000m<sup>2</sup> of contributing area; on the embankment area the DEB will have an allowance for 30m<sup>3</sup> per 1000m<sup>2</sup>. DEBs are limited to 0.3ha or 3000m<sup>2</sup>.

The maximum catchment of a DEB is 3000m<sup>2</sup> with a capacity of 90m<sup>3</sup> as shown on plans, formed by a temporary ridge of compacted earth constructed to create impoundment areas where ponding of runoff can occur and to intercept sediment laden runoff. A boundary bunding, topsoil spread, grass and mulch in all areas at the Right of Way boundary. All areas will be stabilised as soon as possible.

All DEBs shall have a decanting pipe and sediment shall be cleared after rain events in which 20% of the design volume has been occupied.

### 2.3.2. Stormwater Inlet Protection

A barrier across and around the existing cesspits will be used to filter and intercept sediment laden runoff before it enters a reticulated stormwater system.

Stormwater inlet protection provides limited sediment retention and needs frequent maintenance as these clogs easily.

### 2.3.3 Flocculation Management Plan

In addition, flocculation of DEBs will be implemented if determined necessary in discussion with WRC officers during construction. Flocculation using Floc Sock for this site is attached in Appendix 5. The Floc Socks necessary to implement flocculation of the DEBs are to be kept on site at all times, ready for deployment when required.

As the construction progresses, alterations may need to be made to the controls proposed, the locations, and/or the methodology. This will only be done in conjunction with the Contractor and WRC staff involvement and approval.

## 3. SEDIMENT CONTROL AS-BUILTS

All sediment controls are to be certified as being constructed in accordance with this EMP (once approved). Template As-Built certificates are attached for reference in Appendix 6.

## 4. DUST CONTROL

Dust nuisance is a potential effect when vegetation is removed, and the bare soil is exposed to the elements. Windy conditions or the movements of heavy machinery can then generate dust. Due to the location of the property (top of the hill) and proximity to nearby residential areas, dust nuisance shall be monitored constantly, and suppressed by the use of water carts. A water cart will be available on site when required.

Two 25,000 litre water tanks are located on site and will be filled prior to works starting and outside of the water restriction period in place for the Kinloch area. Otherwise, water for the watercart will be sourced by the Contractor from another authorised TDC source.

The Contractor's representative shall ensure after working hours, weekends and/or holiday periods that the daily site dust mitigation is maintained by an appointed person and the staff required to operate the water application system are available to be on call at all times.

Upon completion of each area of earthworks it is envisaged that any remaining areas outside the construction area will be covered in grass, except hardstand areas where metal will be placed.

## 5. CONSTRUCTION TIMETABLE

Construction works are anticipated to commence on site in July 2023. All sediment controls will be constructed prior to any earthworks commencing in the particular catchments serviced by individual controls. The timeframe for completion of earthworks will be somewhat dependant on the nature of the soils encountered and the prevailing weather, although it is expected that all bulk earthworks will be completed within 4 to 6 weeks of commencement. The entire construction is anticipated to be completed within 3 years of starting.

### 5.1. Construction Signs

Prior to the commencement of works on site, including the implementation of this EMP, the contractor shall include the information below as part of the site signs adjacent to the entrance of site works (36 Locheagles Rise), and maintain them throughout the period of works. The signs will display the following information:

- The consent holder
- The main site contractor
- A 24-hour contact telephone number and the name and position of the appointed person
- A clear explanation that the contact telephone number is for the purpose of receiving comment, complaints, and information from the site works.

Signs shall remain in place for the duration of the works and details updated within course of works.

## 5.2. Site Access

Access to the site is via 36 Locheagles Rise (by the Water Reservoir area). The contractor shall ensure that no obstruction to access to the water reservoir happens at any time. A site hut is to monitor and record daily site attendance by contractors.

## 5.3. Hours of Work

Hours of work for heavy machinery shall be limited to:

- Weekdays ..... 7.00am to 7.00pm
- Saturdays ..... 7.30am to 3.00pm
- Sundays and Public Holidays ..... Nil.

Work outside these hours will be permitted for emergencies only.

All heavy machinery shall be well maintained and fitted with appropriate standard mufflers and silencers.

## 5.4. Contractor Programme of Works

This will be provided in short course prior to Earthworks starting.

# 6. MAINTENANCE, MONITORING AND REPORTING PROCEDURES

Prior to earthworks commencing, an on-site meeting will be held between the Contractor and Council staff to discuss the approved Earthworks Management Plan and ensure all measures are in place.

Fortnightly/weekly formal site meetings will be held between the Principal and Contractor at which time the condition of all Erosion and Sediment Control measures will be monitored and any maintenance requirements identified. Representatives of Council are welcome to attend the site meetings to review the sediment controls at the same time. Minutes will be taken at on-site meetings for reporting purposes at the discretion of the Principal. In between site meetings the Contractor will be responsible for maintaining all measures in good operational condition.

At the site meetings, predicted weather patterns for the forthcoming week will be reviewed and any extraordinary precautionary measures taken in the event of a predicted extreme weather event. In any emergency situation resulting from extreme events occurring which exceeds the design event for each control measure, both the Contractor and the Principal will be on 24-hour call-out should emergency works be required. Machinery will be available on site at all times to be used in an emergency situation to mitigate effects of runoff on the site and/or neighbouring properties.

## 7. ARCHAEOLOGICAL DISCOVERIES

If earthworks unearth any Waahi Tapu or archaeological sites, work in the affected area will cease immediately and the appropriate authority will be contacted. The appropriate Tangata Whenua or the Historic Places Trust or the Police will be contacted as required. Subject to any legal requirements of the Police, Heritage New Zealand Pouhere Taonga Act 2014, Antiquities Act 1975 and any other governing legislation, the following protocol shall apply and follow as part of this Earthworks Management Plan for each Stage:

a) Where, during earthworks, any archaeological site, artefact or human remains are accidentally discovered or are suspected to have been discovered:

i. All works in the vicinity shall cease immediately.

*In cases other than suspected human remains:*

ii. The contractor shall immediately secure the area and advise the consent holder and the Heritage New Zealand of the occurrence.

iii. The consent holder must consult with tangata whenua and the Heritage New Zealand to determine what further actions are appropriate to safeguard the site or its contents before work may recommence.

*Where human remains are suspected:*

iv. The contractor shall immediately secure the area in a way which ensures human remains are not further disturbed. The contractor shall advise the consent holder of the steps to take without delay.

v. The consent holder shall notify the police, tangata whenua and Heritage New Zealand of the suspected human remains as soon as practically possible after the remains have been disturbed.

vi. Earthmoving operations in the affected area will remain halted until the police, tangata whenua and the Heritage New Zealand have given approval for earthmoving operations to recommence.

b) Should a waahi tapu be uncovered during earthworks or other construction work, work in the affected area shall stop immediately and the consent holder shall consult with tangata whenua to determine what further actions are appropriate to safeguard the site or its contents before work recommences.

Work will not resume until the appropriate authority has provided the necessary approval.

## 8. REVIEW PROCEDURES

A copy of this Earthworks Management Plan shall be kept on site and available for inspection at all times. Due to a change in construction methodology or as a result of experience on site, should any amendments be required to the Plan then a new Revision will be issued to all affected parties ASAP. All changes must be confirmed in writing by the consent holder and Cheal (acting in a technical capacity) prior to implementation of the necessary changes, where possible. For example, alterations required during an emergency event situation may be made without requiring approval in writing but must be followed up by a revised document approved by all parties ASAP.

## 9. CONTACT DETAILS

The personnel responsible for the design and implementation of this ESCP are:

Design – Lourdes Uriarte of Cheal Consultants.  
Ph 027 281 6804; email [lourdesu@cheal.co.nz](mailto:lourdesu@cheal.co.nz)

Implementation, operation and maintenance TBC.  
Ph (0); email:

Consent Holder – Bruce Bartley of Bartley Family Trust  
Ph 021 941 541; email: [brucebartley1@gmail.com](mailto:brucebartley1@gmail.com)

# Appendix 1

Cheal Topographical Site  
Survey 16666-TP01

and

Asbuilt Plan  
2013-104-AB205



www.cheal.co.nz

**NOTES:**

Asbuilt utilities may have other services in close proximity which are not shown for the purposes of this plan. Please identify existing utility locations and depths with Taupo District Council GIS before any field investigation or construction.

Underground services shown are indicative only. It is the Contractors responsibility to identify existing utility locations and depths prior to construction.

Reduced Levels are in terms of Moturiki 1953 Vertical Datum  
Origin: BP 5 DP 474891  
R.L.: 502.03  
Source: DP 474891  
Contour Interval: 1.00 m

Boundary information has been sourced from DP 474891 and is in terms of New Zealand Geodetic Datum 2000, Mount Eden Circuit.

This plan has used the information captured on Cheal Plan 2013-104-TP002 A to show topographic features on Lot 1 DP 474891. Any changes that have occurred on Lot 1 DP 474891 since this original survey was undertaken in January 2017 will not be shown on this plan.

**Legend:**

- Top of Banks
- Bottom of Banks
- Building Envelope
- Vegetation Restriction

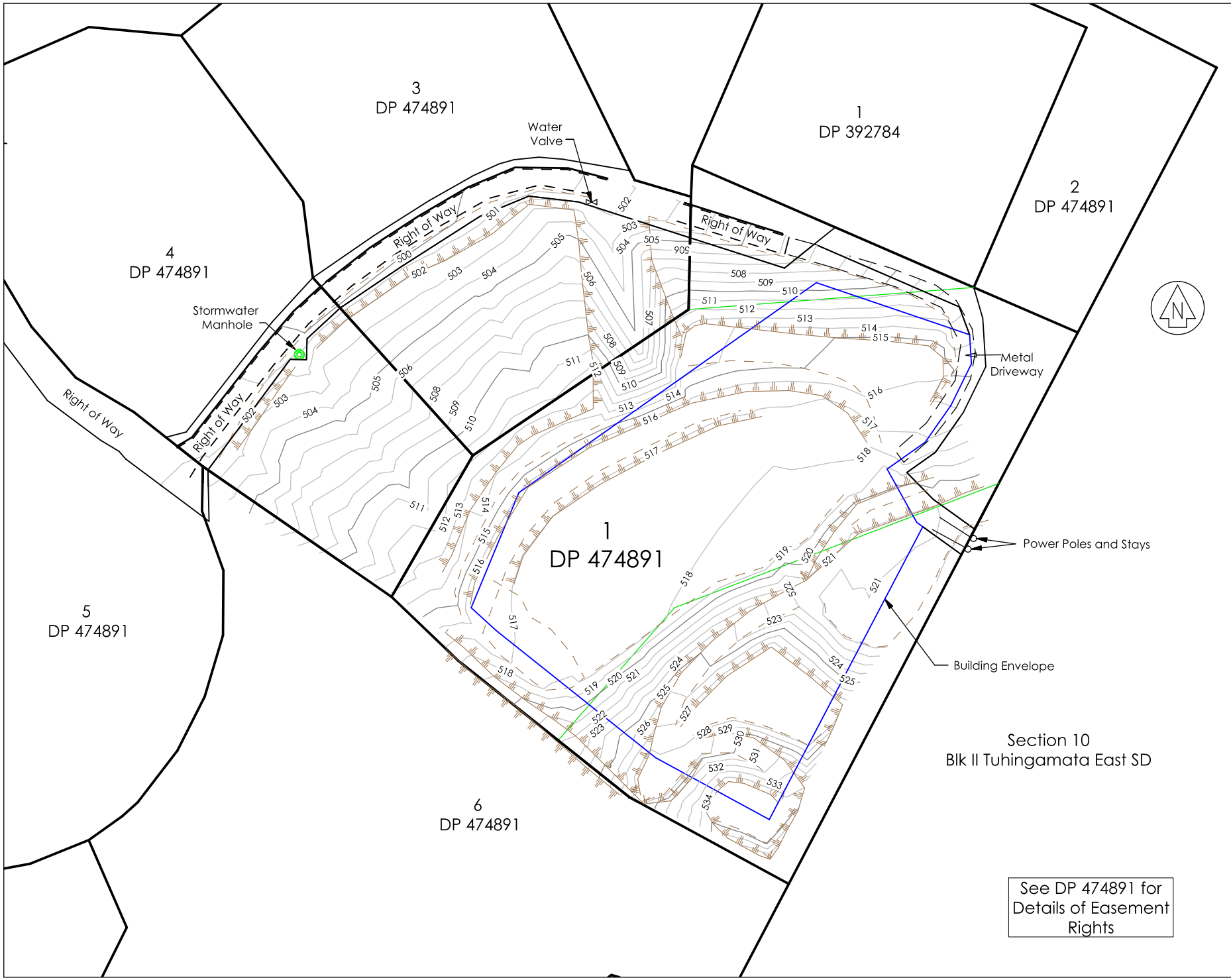

See DP 474891 for Details of Easement Rights

A	30/03/20	For Information	GR	SB	MR
Rev		Amendment	By	CHK	APP

Project Title  
**Bruce Bartley Family Trust**  
**36 Locheagles Rise**  
**Kinloch**

Drawing Title  
**Topographic Survey**  
**of Lot 1 DP 474891 and**  
**Part of Lot 3 and 4 DP 474891**

Surveyed	G.Ripoll	18/03/20	GR
Designed			
Drawn	G.Ripoll	30/03/20	GR
Checked	S.Bowden	30/03/20	SB
Approved	M.Ryder	30/03/20	MR

Status **INFORMATION**

Scale A1	-	A3
A3	1:750	
Drawing Number	16666-TP001	Rev
		A



www.cheal.co.nz

**NOTES:**

Asbuilt utilities may have other services in close proximity which are not shown for the purposes of this plan.  
Please identify existing utility locations and depths with Taupo District Council GIS before any field investigation or construction.

Underground services shown are indicative only.  
It is the contractors responsibility to identify existing utility locations and depths prior to construction.

Reduced Levels are in terms of: Moturiki Vertical 1953  
Origin: RM KB SO 59458  
R.L: 361.50 (Source SO 59458)  
Contour Interval: 1m

**Legend:**

Cut ———  
Fill ———

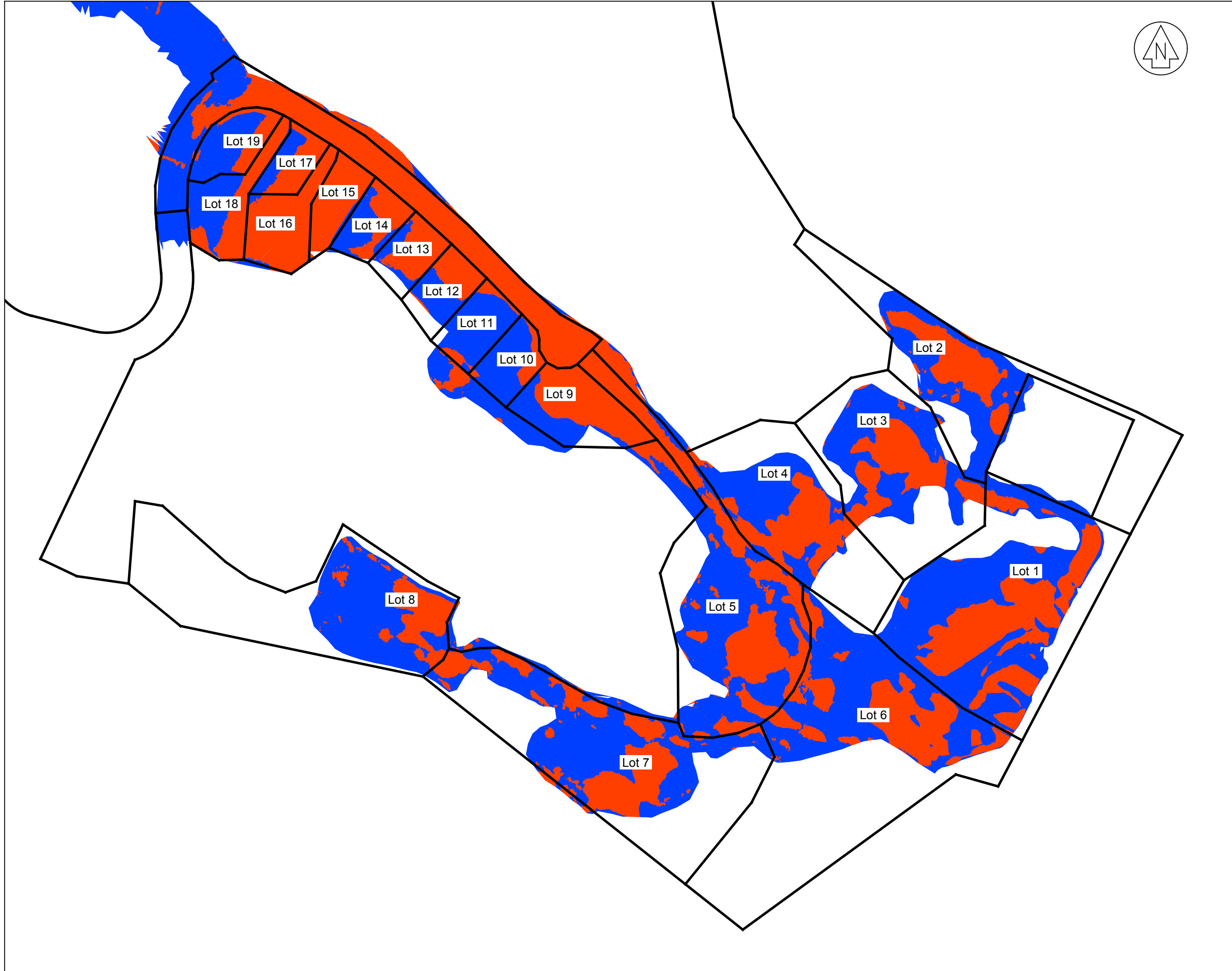

Rev	Date	Amendment	By	Chk	App
A	14/08/14	INFORMATION	MR	RIG	AGM

Project Title  
**LOCHEAGLES LIMITED  
LOCHEAGLES RISE  
KINLOCH**

Drawing Title  
**POST EARTHWORKS  
CUT FILL PLAN**

Surveyed	L. RAINFORD	05/14 - 08/14	pp LR
Designed			
Drawn	M. RYDER	14/08/14	MR
Checked	R. GRAY	14/08/14	RIG
Approved	A. MOSS	14/08/14	AGM

Status **INFORMATION**

Scale A1 - A3  
A3 1:2000 | A3

Drawing Number 2013-104-AB205 | Rev A



## **Appendix 3**

VERTICAL ARTS  
Earthworks Plan RC2.0  
Proposed Final Contour  
Levels

Building Section Plans  
RC4.0 and RC4.1



**Site Information**

Lot 1  
DP 474891

**Site Coverage:**  
Site - 11412 m<sup>2</sup>

Building & Roof - 2130 m<sup>2</sup>  
Building Cover @ 5%  
Allowed- 570.6 m<sup>2</sup>  
Proposed- 2130 m<sup>2</sup> or 18.6%

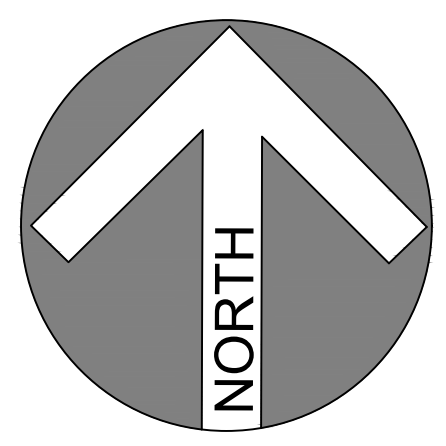

1:250  
0 10M

ISSUE NAME	DATE
PLAN REVIEW	09/08/2022

DRAWING TITLE  
**Overall Site Plan**

SHEET NO.  
**SP-1**

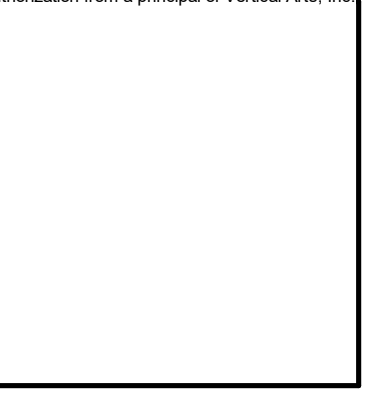

CUT / FILL - METRIC			
Name	Cut	Fill	Net cut/fill

INNER GRADE	1096 m <sup>3</sup>	443 m <sup>3</sup>	-654 m <sup>3</sup>
10m BORDER	761 m <sup>3</sup>	331 m <sup>3</sup>	-430 m <sup>3</sup>
UPPER YARD 002	1821 m <sup>3</sup>	157 m <sup>3</sup>	-1664 m <sup>3</sup>
UPPER YARD 001	621 m <sup>3</sup>	146 m <sup>3</sup>	-475 m <sup>3</sup>
	4299 m <sup>3</sup>	1076 m <sup>3</sup>	-3223 m <sup>3</sup>

GRADE			
DRIVEWAY	225 m <sup>3</sup>	6 m <sup>3</sup>	-219 m <sup>3</sup>
DRIVEWAY	348 m <sup>3</sup>	8 m <sup>3</sup>	-341 m <sup>3</sup>
	574 m <sup>3</sup>	14 m <sup>3</sup>	-560 m <sup>3</sup>

PAD			
MAIN HOUSE PAD	1371 m <sup>3</sup>	0 m <sup>3</sup>	-1371 m <sup>3</sup>
UPPER CY PAD	1352 m <sup>3</sup>	0 m <sup>3</sup>	-1352 m <sup>3</sup>
POOL 2 PAD	54 m <sup>3</sup>	4 m <sup>3</sup>	-50 m <sup>3</sup>
COURTYARD PAD	1029 m <sup>3</sup>	0 m <sup>3</sup>	-1029 m <sup>3</sup>
	3806 m <sup>3</sup>	4 m <sup>3</sup>	-3802 m <sup>3</sup>
Grand total	8679 m <sup>3</sup>	1093 m <sup>3</sup>	-7586 m <sup>3</sup>



**BARTLEY RESIDENCE  
36 LOCHEAGLES RISE,  
KINLOCH, NEW ZEALAND 3377  
#1718**

ISSUE NAME	DATE

DRAWING TITLE  
Earthworks Plan

SHEET NO.

**RC2.0**

5/13/2022 3:04:26 PM



1 BUILDING SECTION  
1 : 100

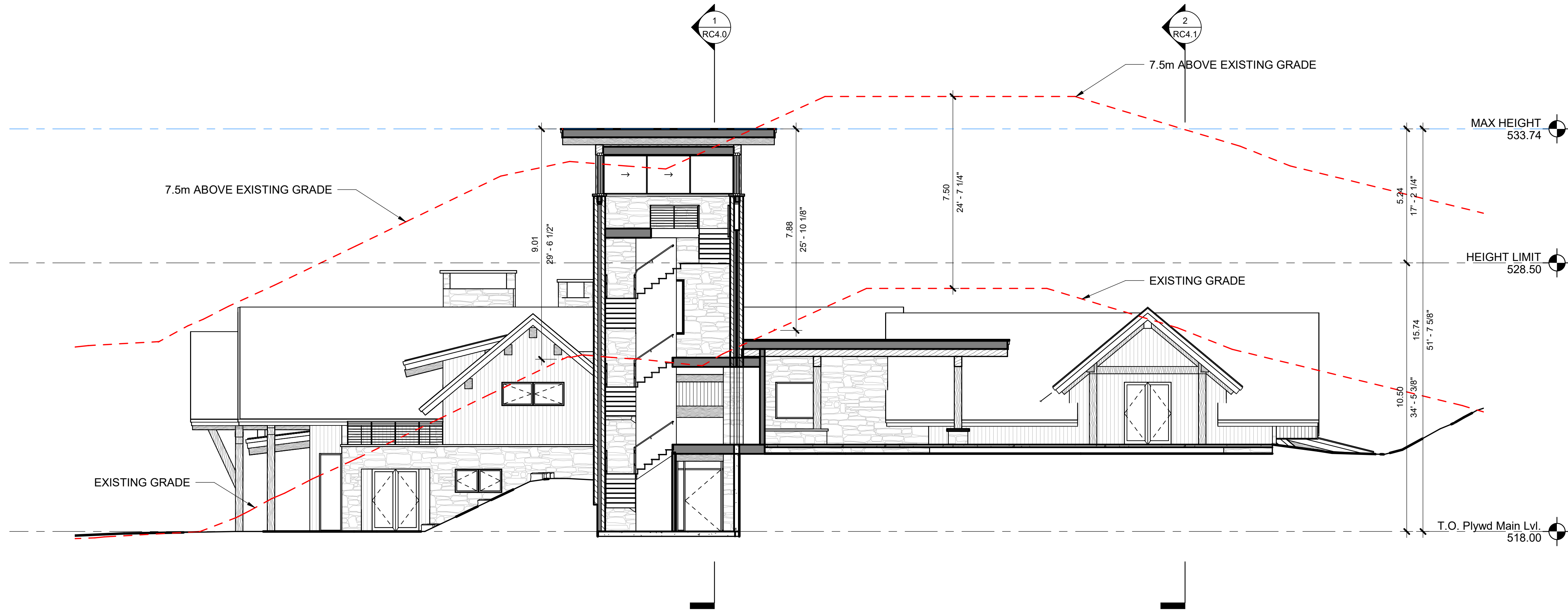

2 BUILDING SECTION  
1 : 100

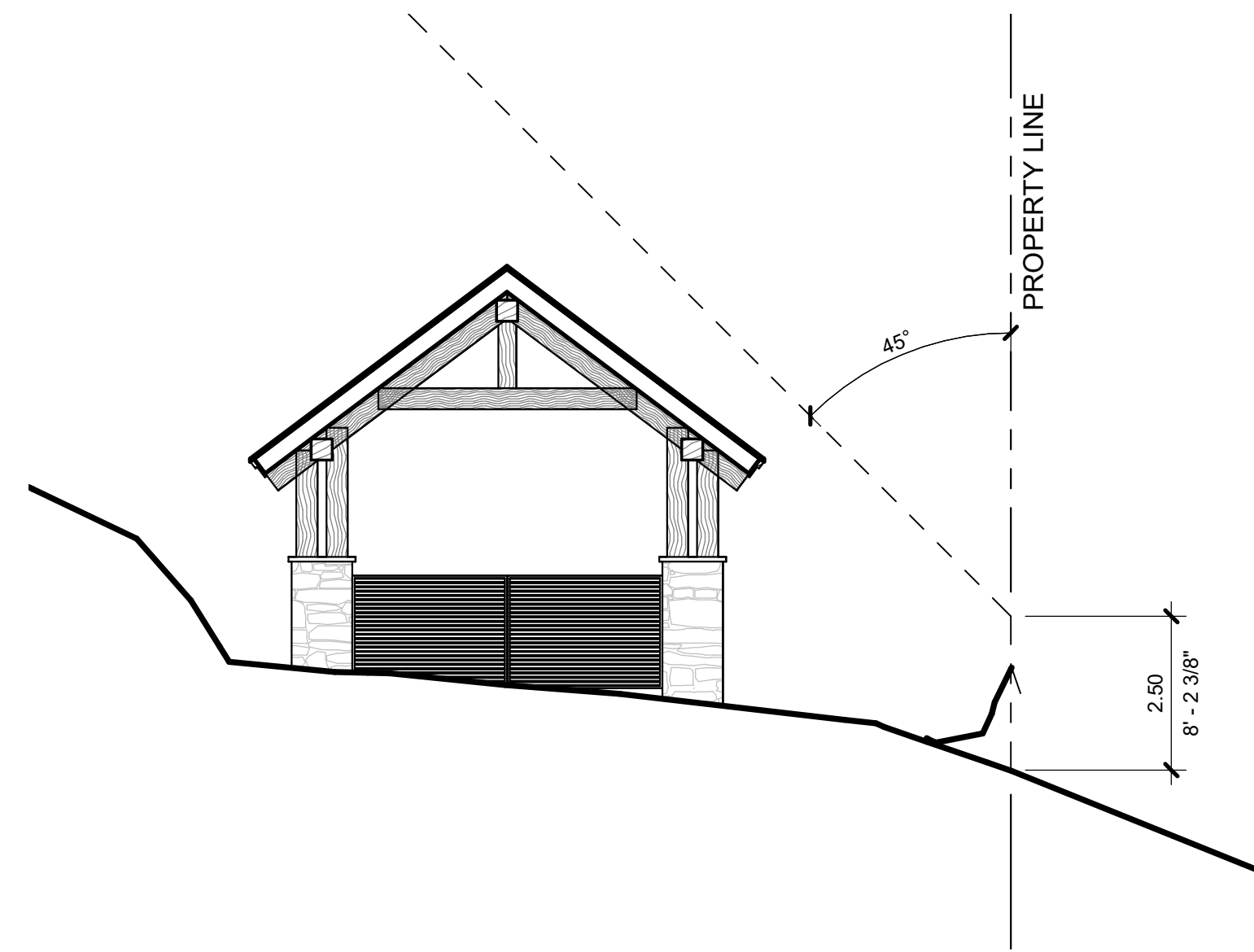

3 GATEHOUSE BOUNDARY COMPLIANCE  
1 : 100

ISSUE NAME	DATE

DRAWING TITLE  
BUILDING SECTIONS  
- RESOURCE  
CONSENT

SHEET NO.

RC4.0



ARCHITECTURE

Design | Planning | Interiors

Copyright VERTICAL ARTS, INC.  
All Rights Reserved

This document, and the ideas and designs incorporated herein, are the property of Vertical Arts Inc. and is not to be used, in whole or in part, for any other project without the written authorization from a principal of Vertical Arts, Inc.

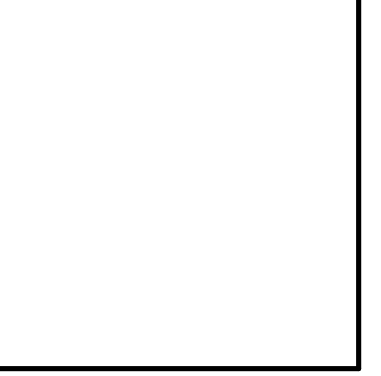

**BARTLEY RESIDENCE**  
**36 LOCHEAGLES RISE,**  
**KINLOCH, NEW ZEALAND 3377**  
**#1718**

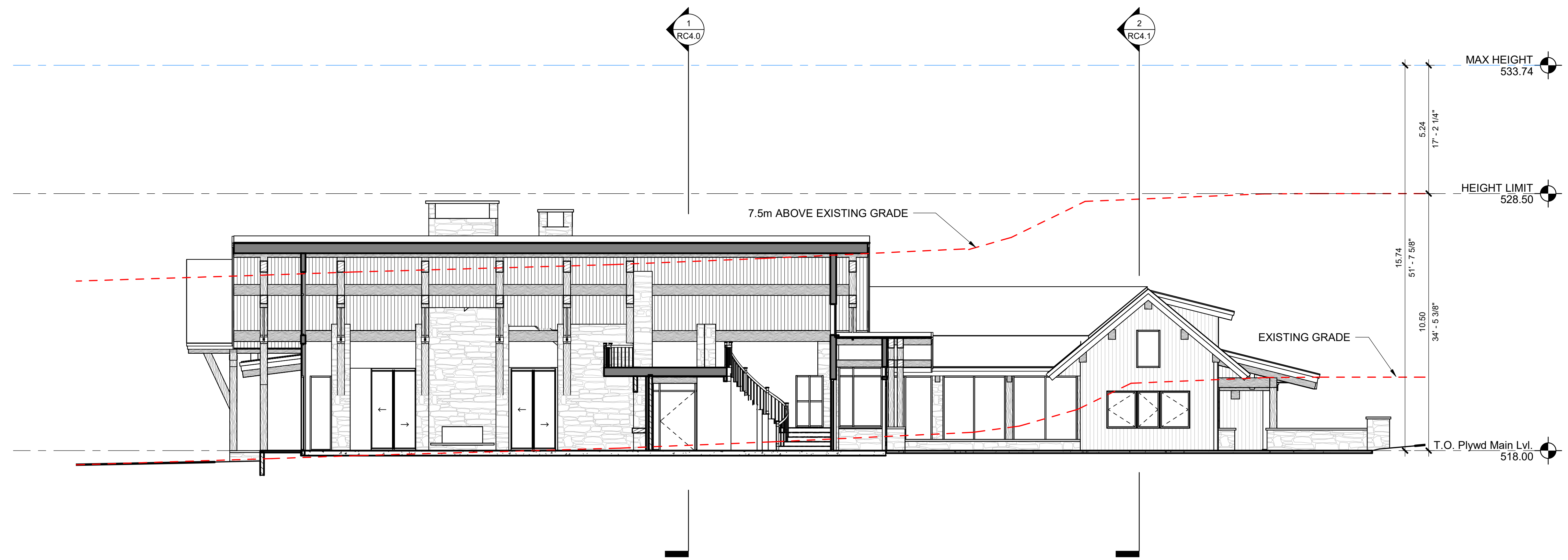

① BUILDING SECTION  
1 : 100



② BUILDING SECTION  
1 : 100

ISSUE NAME	DATE

DRAWING TITLE  
BUILDING SECTIONS  
- RESOURCE  
CONSENT

SHEET NO.

RC4.1

5/13/2022 3:04:29 PM

## **Appendix 4**

Erosion and Sediment  
Control Sketch  
220069-SK001 to SK004



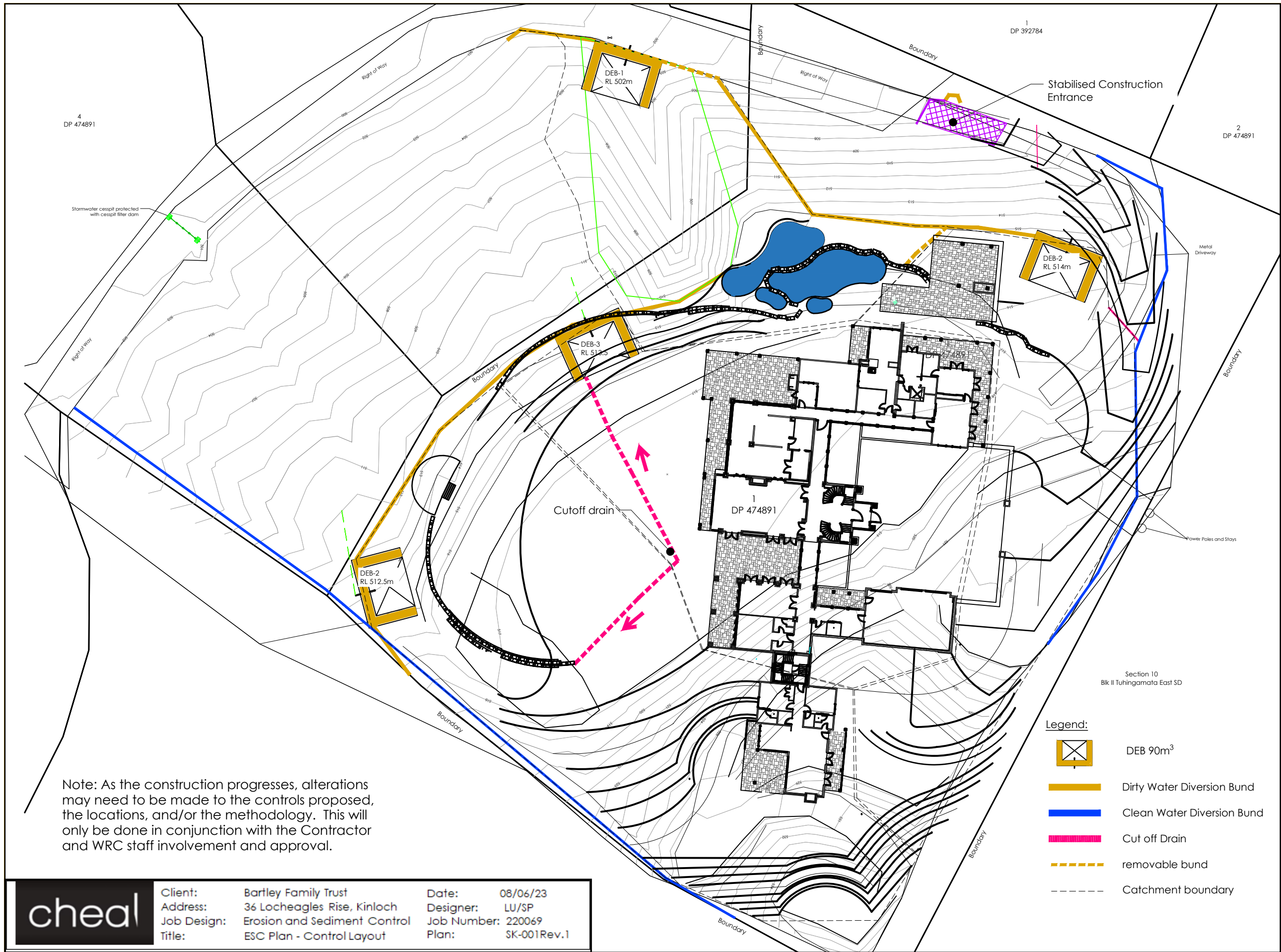

Cheal Standard Drawings

CH-201 – Earthworks  
Sediment & Erosion  
Diversion Bund Details

CH-202 - Earthworks Lot  
Runoff Sediment Control  
Details

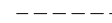

Note: As the construction progresses, alterations may need to be made to the controls proposed, the locations, and/or the methodology. This will only be done in conjunction with the Contractor and WRC staff involvement and approval.

- Legend:
-  DEB 90m<sup>3</sup>
  -  Dirty Water Diversion Bund
  -  Clean Water Diversion Bund
  -  Cut off Drain
  -  removable bund
  -  Catchment boundary

<b>cheal</b>	<b>Client:</b> Bartley Family Trust	<b>Date:</b> 08/06/23
	<b>Address:</b> 36 Locheagles Rise, Kinloch	<b>Designer:</b> LU/SP
	<b>Job Design:</b> Erosion and Sediment Control	<b>Job Number:</b> 220069
	<b>Title:</b> ESC Plan - Control Layout	<b>Plan:</b> SK-001Rev.1

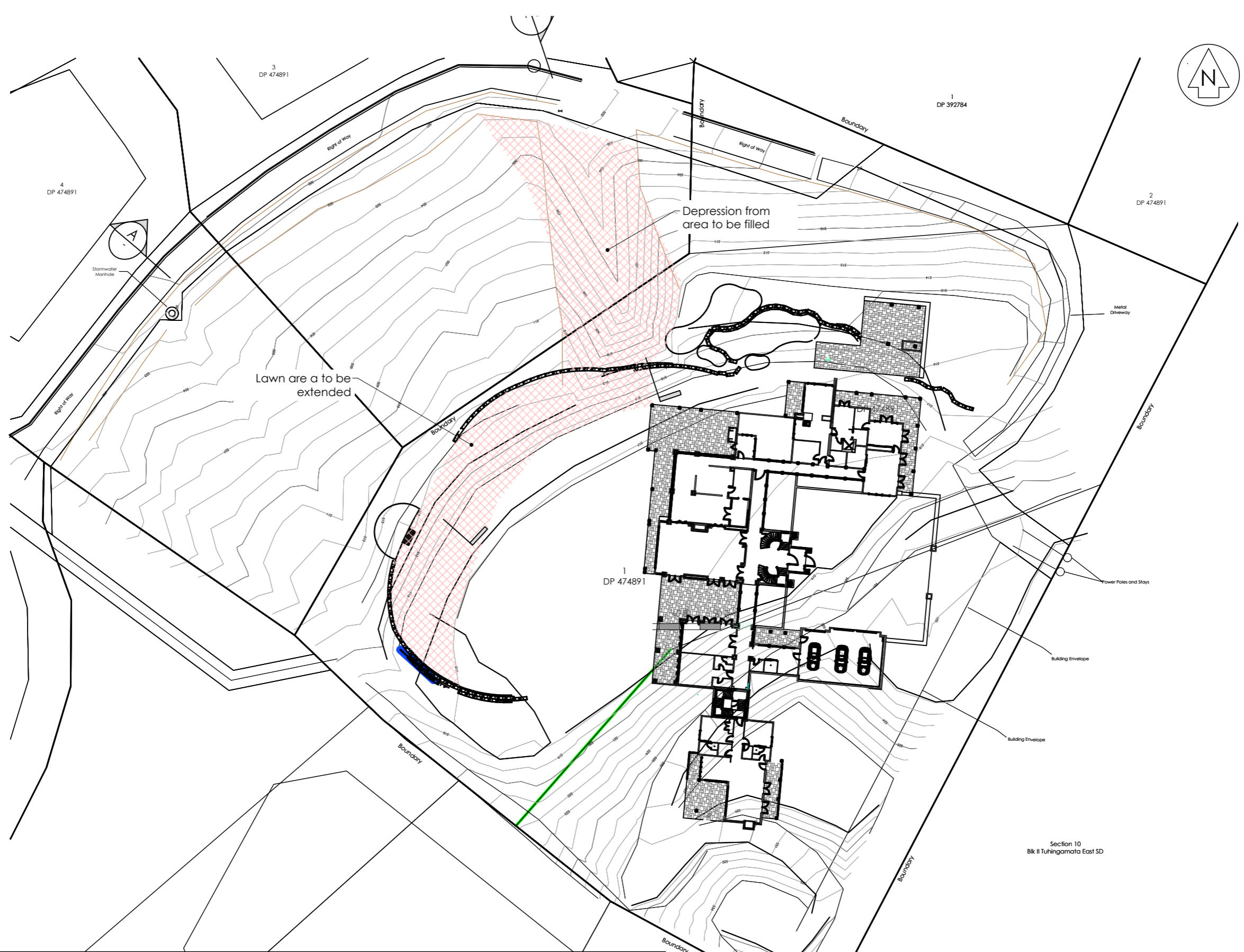

Section 10  
Blk II Tuhingamata East SD

cheal	<b>Client:</b>	Bartley Family Trust	<b>Date:</b>	11/08/2022
	<b>Address:</b>	36 Locheagles Rise, Kinloch	<b>Designer:</b>	LU/SP
	<b>Job Design:</b>	Erosion and Sediment Control	<b>Job Number:</b>	220069
	<b>Title:</b>	Fill Balance Proposed Layout	<b>Plan:</b>	SK-02



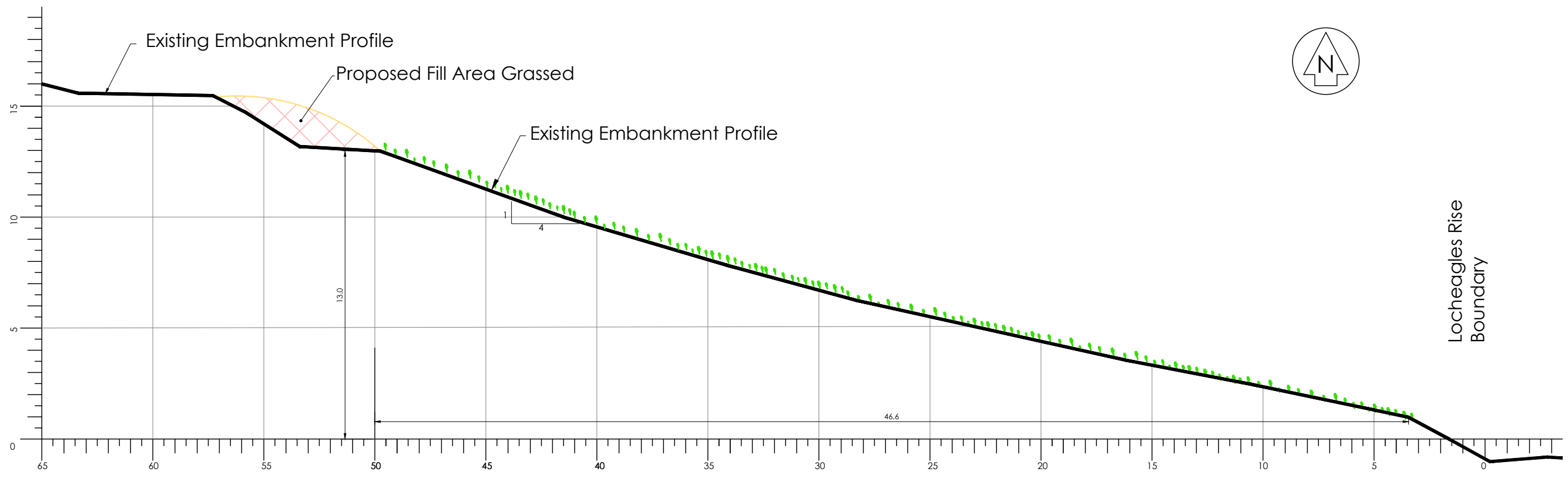

Lawn Extended Area (A)  
Scale 1:100 @ A3

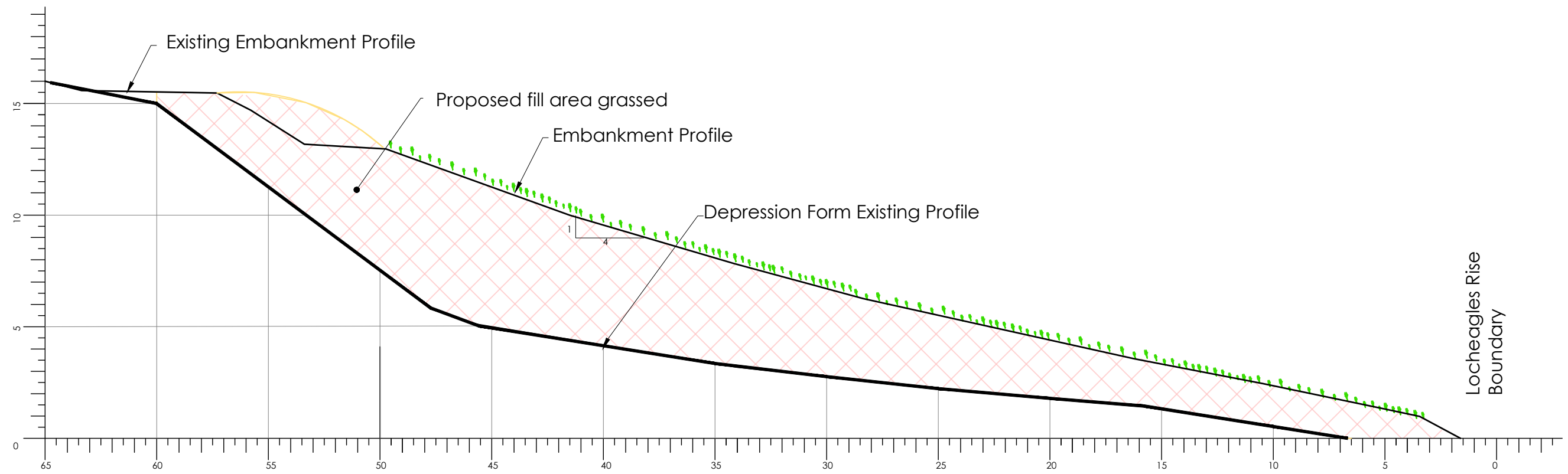

Gully Proposed Fill Section (B)  
Scale 1:100 @ A3

This Lot Area	11,421 m <sup>2</sup>
Lot 3 embankment Area only including gully area	2,356 m <sup>2</sup>
Lot 4 embankment Area only	1,758 m <sup>2</sup>
Earthworks Area	9,850 m <sup>2</sup>
Area without earthworks	3,350 m <sup>2</sup>

3  
474891

1  
DP 392784

2  
DP 474891

4  
DP 474891

Water Valve

Gully Area(Lot3)  
665m<sup>2</sup>



Stormwater Manhole

Lot3  
2,356m<sup>2</sup>  
Area to be Landscaped and planted

DEB-2

Metal Driveway

Right of Way

Lot 4  
1,758m<sup>2</sup>  
Area to be Landscaped and planted

DEB-3

Lot 1  
11,421m<sup>2</sup>

Power Poles and Stays

5  
DP 474891

1  
DP 474891

DEB-4

Building Envelope

Section 10  
Blk II Tuhingamata East SD

6  
DP 474891



Client:	Bartley Family Trust	Date:	08/06/23
Address:	36 Locheagles Rise, Kinloch	Designer:	LU/
Job Design:	Erosion and Sediment Control	Job Number:	220069
Title:	ESC Plan - Catchment Layout	Plan:	SK-004

See DP 474891 for  
Details of Easement  
Rights

Notes:

DEB-1 is located at the lower end of the gully and below the right of way level. Earthworks will be receded to create space for the DEB and access. The DEB area will be the last part of the fill works. This to be filled during good weather window.

DEB-2 Catchment covers mostly the building platform.

DEB-3 Catchment cover the eastern side of the Lot following the access to the building area.

DEB-4 Cathment in pink shade. Cover the eastern side of the building where the natural contour fall towards Lot 4. An existing bund is located between the boundary with Lot 6 DP474891, where the contours fall away from this site.

As the construction progresses, alterations may need to be made to the controls proposed, the locations, and/or the methodology. This will only be done in conjunction with the Contractor and WRC staff involvement and approval.

**NOTES:**

1. All work shall be done in accordance with the Taupo District Council Code of Practice.
2. Contractor to locate and identify existing utility location and depths prior to construction. The project engineer shall be informed of any discrepancies to the information depicted on these plans immediately for revised drawings.
3. Contractor shall install and maintain all stormwater, dust, and erosion control during construction as per earthworks management plan and the Waikato Regional Council Erosion and Sediment Control - "Guidelines for soil disturbing activities".
4. All disturbed areas shall be re-topsoiled and grassed within 30 days upon completion of contract works. Dust control shall be maintained until grassed areas have become established.

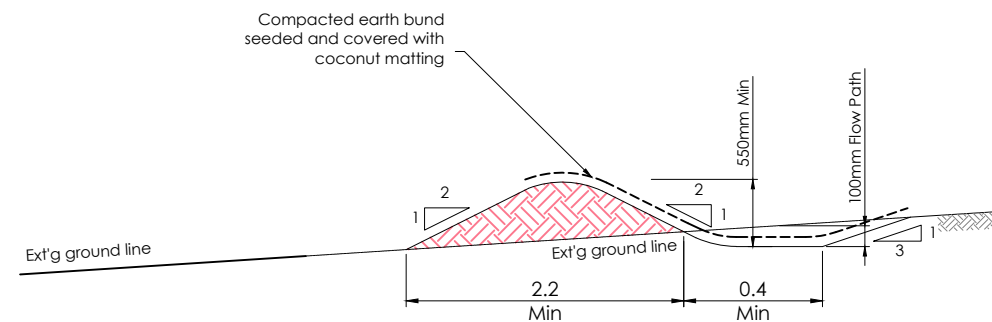

Detail 1 Clean Water Diversion Bund  
Scale N.T.S.

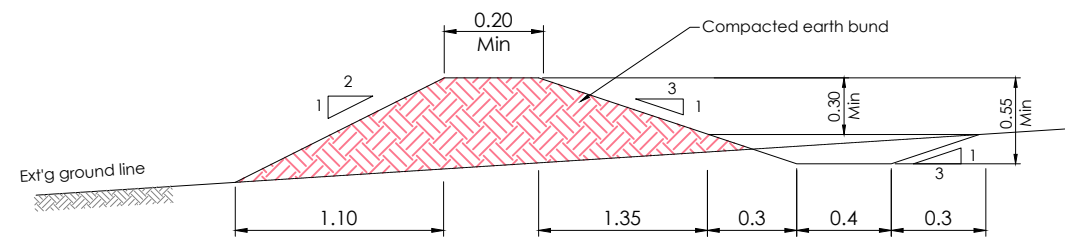

Detail 2 Dirty Water Diversion Bund & Cut Off Drain  
Scale N.T.S.

Rev	Date	Amendment	By	Chk	App
1	10/03/21	For Construction	PH	SP	TWB

Project Title  
Cheal Consultants Ltd  
Standard Details

Drawing Title  
Earthworks  
Sediment & Erosion  
Diversion Bund Details

Surveyed	-	-	-
Designed	-	-	-
Drawn	P.Harris	10/03/21	PH
Checked	S.Prasad	10/03/21	SP
Approved	T.Brand	10/03/21	TWB

Status **CONSTRUCTION**

Scale	A1	N.T.S.	A1
	A3	N.T.S.	

Drawing Number	CH-201	Rev	1
----------------	--------	-----	---

**NOTES:**

- All work shall be done in accordance with the Taupo District Council Code of Practice.
- Contractor to locate and identify existing utility location and depths prior to construction. The project engineer shall be informed of any discrepancies to the information depicted on these plans immediately for revised drawings.
- Contractor shall install and maintain all stormwater, dust, and erosion control during construction as per earthworks management plan and the Waikato Regional Council Erosion and Sediment Control - "Guidelines for soil disturbing activities".
- All disturbed areas shall be re-topsoiled and grassed within 30 days upon completion of contract works. Dust control shall be maintained until grassed areas have become established.

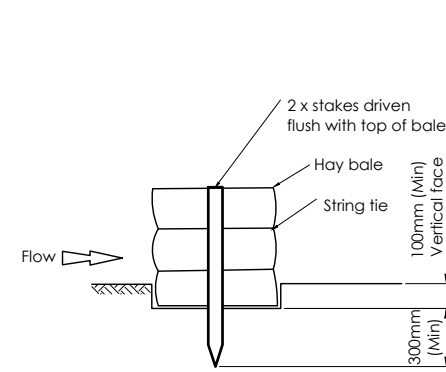

**Detail 1 Silt Fence**  
Scale N.T.S.

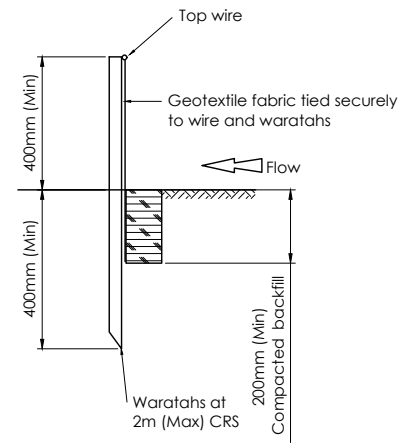

**Detail 2 Silt Fence**  
Scale N.T.S.

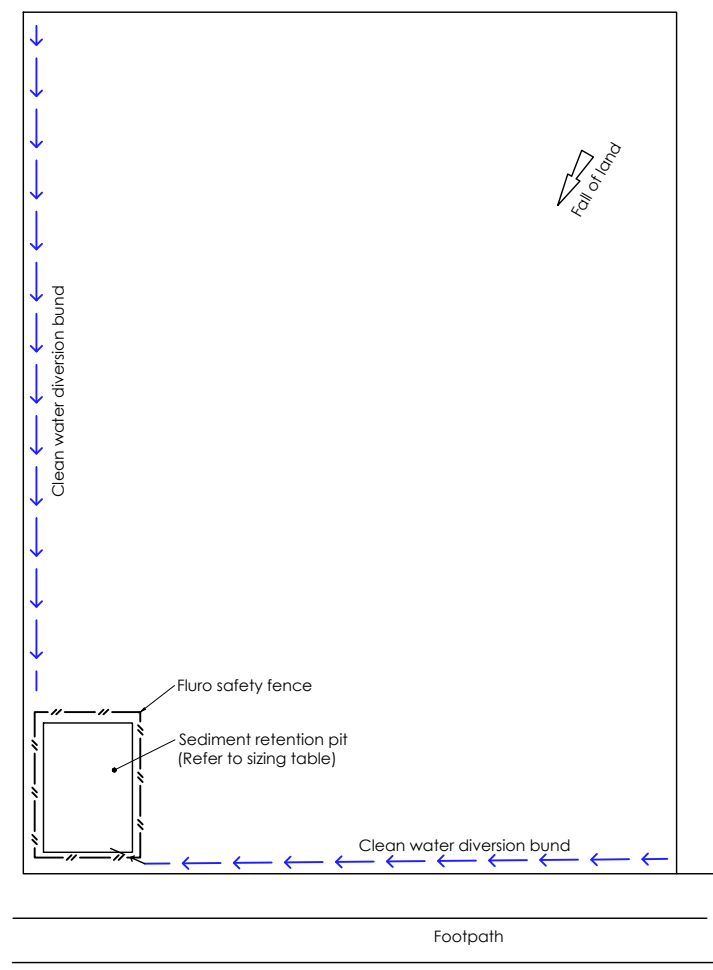

**Pre Lot Development**  
(NTS)

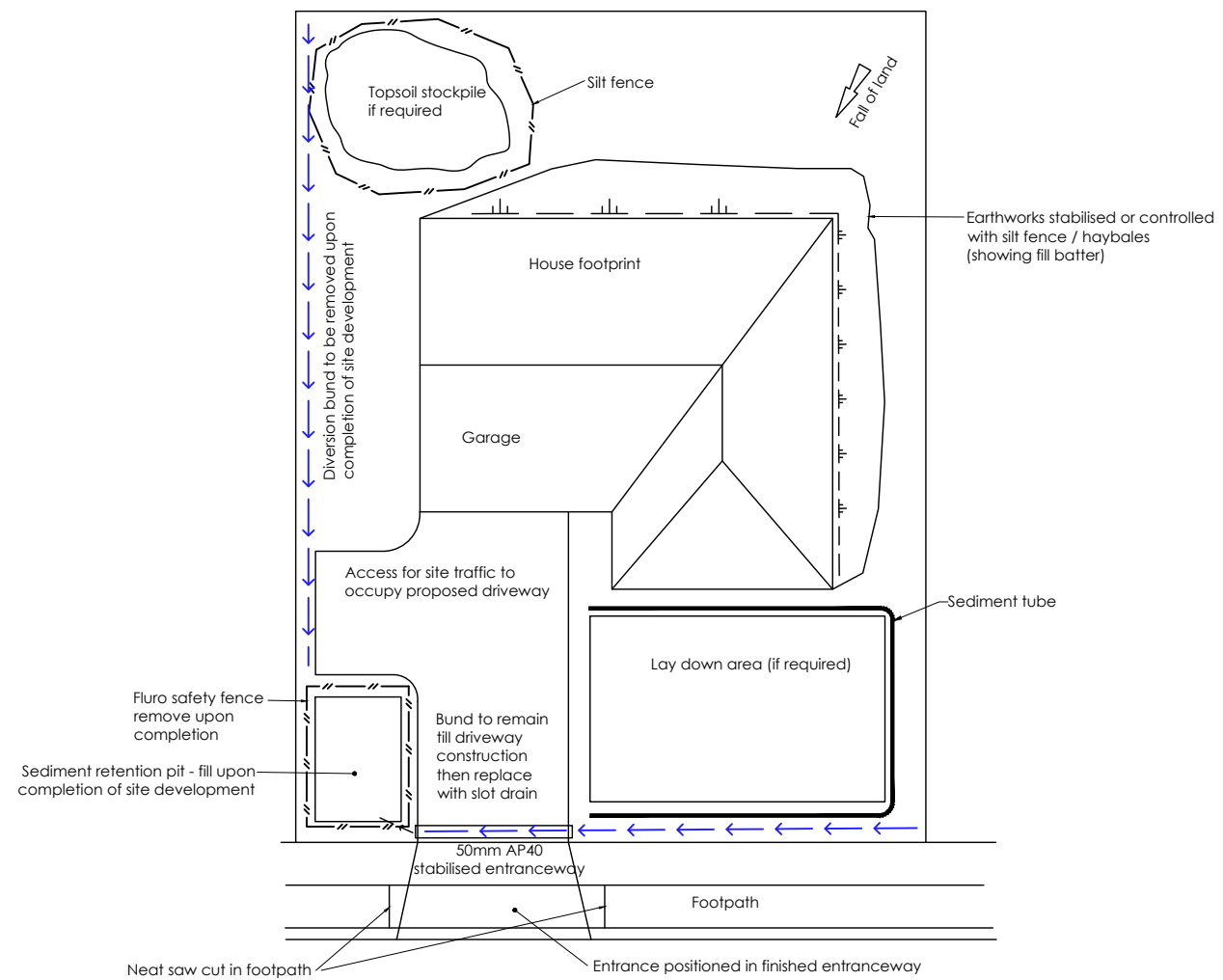

**During Lot Development**  
(NTS)

Sizing Table			
	Lot Sizes (m <sup>2</sup> )	Pit Volume (m <sup>3</sup> )	Pit dimensions (m)
Based on 10 year, 1 hr storm L/10 C - 0.5 No loss to soakage	≤ 500	1	3L x 3W x 1.2D
	500 - 900	20	4L x 4W x 1.2D
	900 - 1100	25	5L x 4W x 1.2D
	1100 - 1300	30	5L x 5W x 1.2D
	1300 - 1700	38	5L x 5W x 1.5D

Rev	Date	Amendment	By	Chk	App
1	10/03/21	For Construction	PH	SP	TWB

Project Title  
**Cheal Consultants Ltd  
Standard Details**

Drawing Title  
**Earthworks  
Lot Runoff Sediment Control  
Details**

Surveyed	-	-	-
Designed	-	-	-
Drawn	P.Harris	10/03/21	PH
Checked	S.Prasad	10/03/21	SP
Approved	T.Brand	10/03/21	TWB

Status **CONSTRUCTION**

Scale A1 N.T.S. | A1  
A3 N.T.S.

Drawing Number CH-202 | Rev 1

## **Appendix 5**

Relevant Sections from  
WRC Guidelines

# Stabilised construction entrance



### DEFINITION

A stabilised pad of aggregate on a filter cloth base located at any point where traffic will be entering or leaving a construction site.

### PURPOSE

To prevent site access points from becoming sediment sources and to help minimise dust generation and disturbance of areas adjacent to the road frontage by giving a defined entry/exit point.

### APPLICATION

Use a stabilised construction entrance at all points of construction site ingress and egress, with a construction plan limiting traffic to these entrances only. They are particularly useful on small construction sites but can be used for all projects.

### DESIGN

- Clear the entrance and exit area of all vegetation, roots and other unsuitable material and properly grade it.
- Provide drainage to carry run off from the stabilised construction entrance to a sediment control measure.
- Place aggregate to the specifications below and smooth it.

Stabilised construction entrance

#### AGGREGATE SPECIFICATIONS

Aggregate size	50-75mm washed
Thickness	150mm minimum
Length	10m minimum
Width	4m minimum

### Maintenance

Maintain the stabilised construction entrance in a condition to prevent sediment from leaving the construction site. After each rainfall inspect any structure used to trap sediment from the stabilised construction entrance and clean out as necessary. When wheel washing is also required, ensure this is done on an area stabilised with aggregate which drains to an approved sediment retention facility.

## 2.2 Contour Drain



**Plate 2: Contour Drain**

### *Definition*

A temporary ridge or excavated channel, or combination of ridge and channel, constructed to convey water across sloping land on a minimal gradient.

### *Purpose*

To break overland flow down disturbed slopes by limiting slope length and thus the erosive power of runoff, and to divert sediment laden water to appropriate controls or stable outlets.

### *Application*

Use contour drains in the following situations:

- At intervals across disturbed areas to shorten overland flow distances.
- As temporary or daily controls.
- To split and direct flow from disturbed areas to runoff diversion channels/bunds.

### *Design (refer to Figure 4)*

Ensure gradients are no greater than 2 percent and the contour drains are kept as short as practicable in order to minimise erosion. The

positioning of contour drains is often determined by the necessity for stable outfalls, but in general the following spacing applies:

- Immediately carry out any maintenance that is required.

**Table 1: Positioning of Contour Drains**

Slope of Site (%)	Spacing of Contour Drains (m)
5	50
10	40
15	30

**Maintenance**

- Install contour drains at the end of each day.
- Inspect contour drains after every rainfall and during periods of prolonged rainfall.

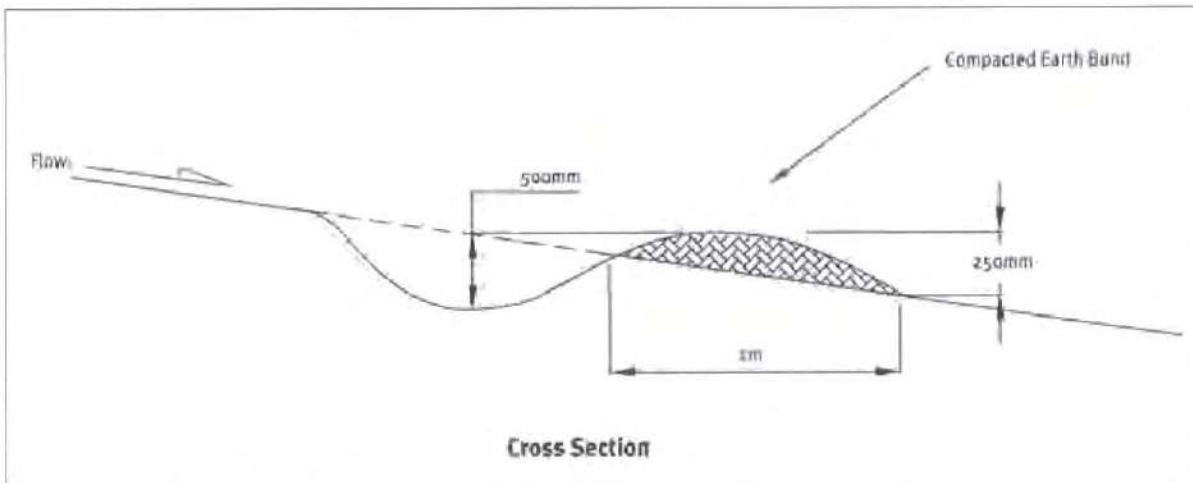

**Figure 4: Contour Drain**



# Decanting earth bund



## DEFINITION

A temporary berm or ridge of compacted earth constructed to create impoundment areas where ponding of run off can occur, and suspended material can settle before run off is discharged.

## PURPOSE

Used to intercept sediment-laden run off and reduce the amount of sediment leaving the site by detaining sediment-laden run off.

## APPLICATION

Decanting earth bunds can be constructed across disturbed areas and around construction sites and subdivisions. Keep them in place until the disturbed areas are permanently stabilised or adequately replaced by other means.

Decanting earth bunds can assist the settling of sediment laden run off, and are particularly useful for controlling run off after topsoiling and grassing before vegetation becomes established. Where works are occurring within the berm area, compact the topsoil over the berm area as bunds adjacent and parallel to the berm. This will act as an impoundment area and controlled outfall while also keeping overland flow away from the construction area.

## DESIGN

- Decanting earth bunds need a constructed outlet structure and spillway, (see follow sections of this guide). The depth should be measured from the base of the decanting earth bund to the top of the primary spillway.
- Construct the decanting earth bunds such that the maximum contributing catchment does not exceed 0.3ha
- Lay the discharge pipe at a 1-2 per cent gradient, compact fill appropriately and incorporate an anti-seep collar.
  - Ensure all anti-seep collars and their connections are watertight.
- Use a flexible thick rubber coupling to provide a connection between the decant arm and the primary spillway or discharge pipe. Fasten the flexible coupling using strap clamps and glue and /or screws to prevent it coming off.
- Ensure the section of pipe leading through the decanting earth bunds and continuing downslope below the decanting earth bunds is non-perforated.
- On earthwork sites with slopes less than 10 per cent and less than 200m in length, construct the decanting earth bund with a minimum volume of 2 per cent of the contributing catchment (20m<sup>3</sup> for each 1000 square metres of contributing catchment).
- On sites with slopes greater than 10 per cent and/or 200m in length, construct decanting earth bunds with a minimum volume of 3 per cent of the contributing catchment (30m<sup>3</sup> capacity for each 1000 square metres of contributing catchment).

- Where possible, install the discharge pipes through the embankment as the embankment is being constructed.
- Fully stabilise the external batter face by vegetative or other means immediately after construction.
- Ensure all external bare areas associated with the decanting earth bund are stabilised in a manner consistent with the guidelines, such as mulch, cloth or vegetation.

## DESIGN – EMERGENCY SPILLWAY

**Stabilise the emergency spillway by lining it with a strong woven low permeability geotextile overlaid with a soft non-woven needle punched geotextile. Ensure the geotextile is pinned at 0.5m centres over the full area of the emergency spillway.**

If there is sand, pumice or other erodible material under the spillways geotextile lining, install a waterproof layer underneath the geotextile, and an alternative method to pinning the geotextile is as follows:

- Bury the edges of the geotextile as per Figure 1.
- Connect a No 8 gauge wire between two waratah standards on either side of the spillway invert, tighten to hold the geotextile down as shown in Figure 1.
- If there is sand, pumice or other erodible material in the decanting earth bund embankment then an antiseep collar must be installed during the construction of the embankment.
- Ensure that all decanting earth bund embankments are compacted appropriately, particularly around the outlet pipe.
- Where possible, construct emergency spillways in well vegetated, undisturbed ground (not fill) and discharge over long grass. The emergency spillway must be located behind the decant system as far away as possible from the inlet.
- If the emergency spillway is constructed on exposed soil, provide complete erosion protection by means such as grouted riprap, asphalt, erosion matting/ geotextile or concrete.
- Construct the emergency spillway with a minimum of 100-150mm freeboard height above the primary spillway invert.
- The minimum emergency spillway dimensions are 2 metres wide with 250mm freeboard

**Figure 1:**

**Connect to waratah on both sides, tighten wire**



<b>Waratahs</b>	
<b>No 8 gauge wire</b>	

## DESIGN – OPTIONAL FOREBAY

Benefits include the ability to clean deposition from the front of the control structure without damaging the 'clean' discharge side of the control.

- Construct a forebay with a volume equal to 10 percent of the pond design volume.
- The forebay is to extend the full width of the main pond and is to be 0.5 to 1 m deep.
- Inlets into the forebay are to be stabilised.
- Access to the forebay is to be maintained at all times to allow easy and frequent removal of accumulated sediments by an excavator.
- Sediment should also be removed after every large storm event and or when 20% of the pond volume is accumulated sediment.

**Figure 2:**

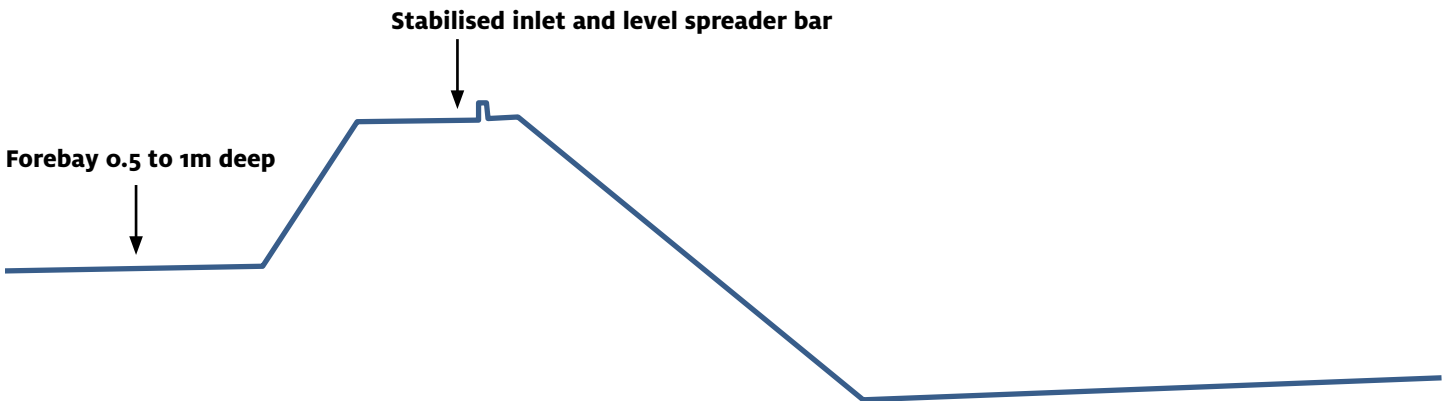

## DESIGN – T-BAR DECANT

T-bar decants must be able to operate through the full live storage depth of the sediment retention pond.

- Position the decant inlet to provide 50 per cent live storage volume with a minimum distance of 5m of flat ground from the inlet. Otherwise raise the inlet so the dead storage level extends out at least this far.
- The decant rate is to be equal to 3 litres per second per hectare. Set the decant rate by drilling the correct amount of 10mm holes in the decant. For a 1,000 square metre contributing catchment 13 X 10mm holes will provide 0.3 litres per second. For a 1,500 square metre contributing catchment 20 x 10mm holes will provide 0.45 litres per second.
- The DEB must be set up so that all inflows enter as far as possible away from the decant.
- Ensure that a primary spillway (upstand riser) is constructed as part of the T-Bar decant, as detailed in figure 3.
- Ensure that the T-bar decant float is securely fastened with steel strapping directly on top of the decant arm and weight it to keep the decant arm submerged just below the surface through all stages of the decant cycle. This will also minimise the potential for blockage of the decant slots by floating debris.
- Position the T-bar decant at the correct height by supporting the decant arm between waratahs as detailed in figure 3.

**Figure 3: 40mm decant with upstand for decanting earth bund.**

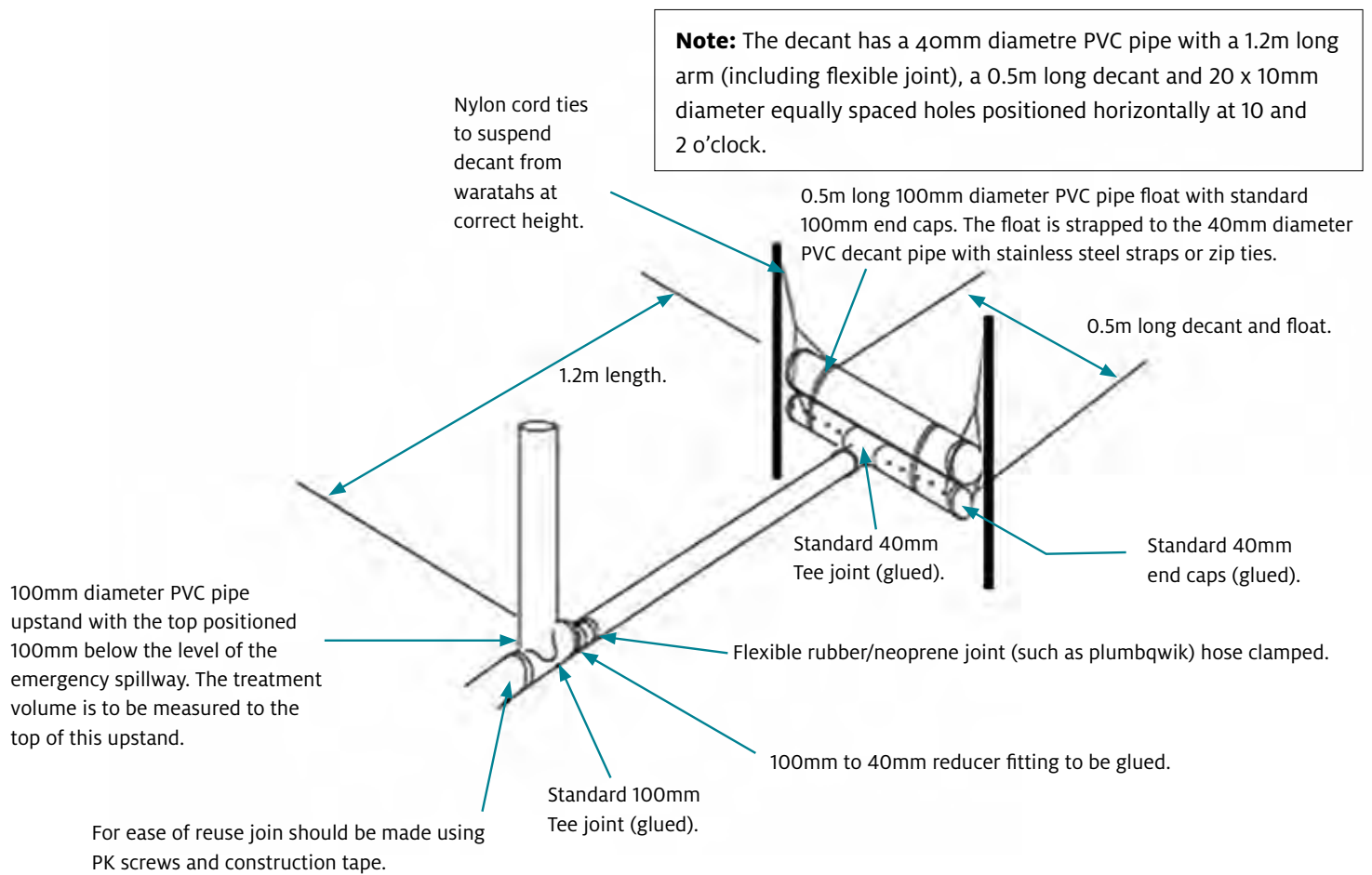

## MAINTENANCE

Inspect and maintain decanting earth bunds regularly and after each rainfall event to check for accumulated sediment which may cause overtopping. Check any discharge points for signs of scouring and install further armouring or other stabilisation if scouring is evident.

## 7. Floc Socks



Floc socks are powdered chemical coagulant and/or flocculant contained in a permeable material that allows the dissolution and therefore the dosing of chemical into a stream of water. As water from a rain event flows over the sock, powdered chemical gets dissolved based on the amount of water which it comes into contact with thereby dosing the chemical directly into the flow. The sediments then settle out after the Floc Sock due to the addition of the chemical.

Floc Socks should be placed directly into an entrance channel into a DEB and is only suitable for very small catchment areas. They should be placed around 5 m up the entrance channel prior to the DEB to allow some mixing of the chemical via the turbulence generated by flowing through the channel and entry into the DEB. The Floc Sock should be placed perpendicular to the flow through the channel to provide varying dosing depending on the volume of water passing the sock. This allows more chemical to be dosed during high rainfall events and less during low rainfall events. The Floc Sock should be properly secured to the ground to prevent washing out in high rainfall.

Based on the catchment area provided Erosion Control Co. recommends that the Floc Sock be replaced after every 25 mm of rain (based on Erosion Control Co. Floc Sock).



# Silt fence



### DEFINITION

A temporary barrier of woven geotextile fabric used to intercept run off, reduce its velocity and impound sediment laden run off from small areas of disturbed soil.

### PURPOSE

To detain flows from run off so that deposition of transported sediment can occur through settlement.

Silt fences can only be used to intercept sheet flow. Do not use silt fences as velocity checks in channels or place them where they will intercept concentrated flow.

### APPLICATION

- On low gradient sites or for confined areas where the contributing catchment is small, such as short steep batter fills and around watercourses.
- To delineate the limit of disturbance on an earthworks site such as riparian areas or bush reserves.
- To store run off behind the silt fence without damaging the fence or the submerged area behind the fence.
- Do not install silt fences across watercourses or in areas of concentrated flows.

### DESIGN

- Ensure silt fence height is a minimum of 400mm above ground level.
- Place supporting posts/waratahs for silt fences no more than 2m apart unless additional support is provided by tensioned wire (2.5mm HT) along the top of the silt fence. Where a strong woven fabric is used in conjunction with a wire support, the distance between posts can be extended up to 4m. Double the silt fence fabric over and fasten to the wire and posts with wire ties or cloth fastening clips at 150mm spacing. Ensure supporting posts/waratahs are embedded a minimum of 400mm into the ground.
- Always install silt fences along the contour. Where this is not possible or where there are long sections of silt fence, install short silt fence returns, projecting upslope from the silt fence to minimise concentrations of flows. Silt fence returns are a minimum of 2m in length, can incorporate a tie back and are generally constructed by continuing the silt fence around the return and doubling back to eliminate joins.
- Join lengths of silt fence by doubling over fabric ends around a wooden post or batten or by stapling the fabric ends to a batten and butting the two battens together as shown in figure 1 (overleaf).
- Maximum slope lengths, spacing of returns and angles for silt fences are shown in table 1 (overleaf).
- Install silt fence wings at either end of the silt fence projecting upslope to a sufficient height to prevent outflanking.

- Where impounded flow may overtop the silt fence, crossing natural depressions or low points, make provision for a riprap splash pad or other outlet protection device.
- Do not use silt fences in catchments of more than 0.25ha.
- Where water may pond behind the silt fence, provide extra support with tie backs from the silt fence to a central stable point on the upward side. Extra support can also be provided by stringing wire between support stakes and connecting the filter fabric to this wire.

## CONSTRUCTION SPECIFICATIONS

- Use silt fence material appropriate to the site conditions and in accordance with the manufacturer's specifications.
- Excavate a trench a minimum of 100mm wide and 200mm deep along the proposed line of the silt fence. Install the support posts on the downslope edge of the trench and silt fence fabric on the upslope side of the support posts to the full depth of the trench. Backfill the trench with compacted soil.
- Use supporting posts of tanalised timber a minimum of 50mm square, or steel waratahs at least 1.5m in length.
- Reinforce the top of the silt fence fabric with a wire support made of galvanised wire of a minimum diameter of 2.5mm. Tension the wire using permanent wire strainers attached to angled waratahs at the end of the silt fence.
- Where ends of silt fence fabric come together, ensure they are overlapped, folded and stapled to prevent sediment bypass.

## MAINTENANCE

- Inspect silt fences at least once a week and after each rainfall. Make any necessary repairs when bulges occur or when sediment accumulation reaches 50 per cent of the fabric height.
- Any areas of collapse, decomposition or ineffectiveness need to be immediately replaced.
- Remove sediment deposits as necessary to continue to allow for adequate sediment storage and reduce pressure on the silt fence. Ensure that the sediment is removed to a secure area.
- Do not remove silt fence materials and sediment deposition until the catchment area has been appropriately stabilised. Stabilise the area of the removed silt fence.

Table 1

Silt fence design criteria			
Slope steepness (%)	Slope length (m) (Maximum)	Spacing of returns (m)	Silt fence length (m) (Maximum)
Flatter than 2%	Unlimited	N/A	Unlimited
2-10%	40	60	300
10-20%	30	50	230
20-33%	20	40	150
33-50%	15	30	75
> 50%	6	20	40

Figure 1

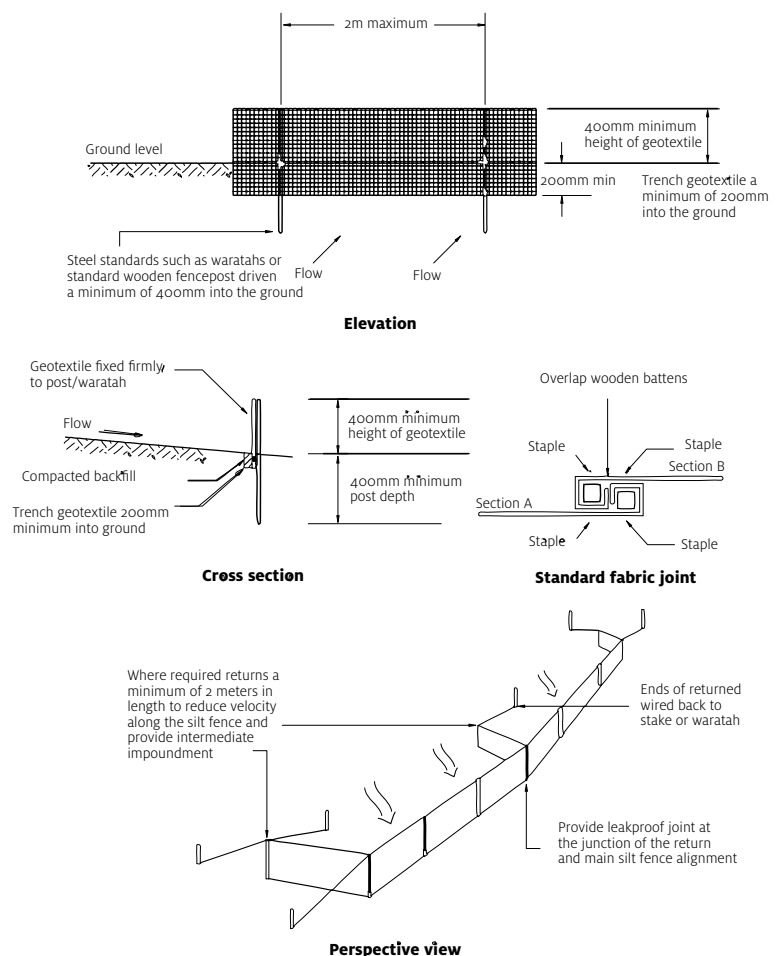

## **Appendix 6**

Sediment Control  
As-built Templates



# Decanting Earth Bund (DEB) As-built Certification Sheet

**Bund name/number:** \_\_\_\_\_

Contributing catchment area (m <sup>2</sup> )		
Dead storage volume and height	Volume (m <sup>3</sup> )	Height
Live storage volume and height	Volume (m <sup>3</sup> )	Height
Bunds adequately compacted	Y <input type="checkbox"/>	N <input type="checkbox"/>
Emergency spillway width and depth	Width	Depth
Emergency spillway stabilisation type	Type	
Discharge point stabilised?	Y <input type="checkbox"/>	N <input type="checkbox"/>
Freeboard between primary and emergency spillway?	mm	
Decant discharge rate	litre per second	
Flexi join attached securely sealed	Y <input type="checkbox"/>	N <input type="checkbox"/>
Anti-seep collars installed (Pumice or sand soils only)	Y <input type="checkbox"/>	N <input type="checkbox"/>
Waikato Regional Council approved variations to device (please list)		

Please sign below to confirm that the information in this sheet is accurate and the device identified on this sheet has been constructed in accordance with the Waikato Regional Council approved erosion and sediment control plan for the site and the “Erosion and Sediment Control Guidelines for Soil Disturbing Activities”, January 2009 document or Waikato Regional Council approved variations.

Suitably qualified person (name and company): \_\_\_\_\_

Signed and dated: \_\_\_\_\_

Please provide surveyed drawings of as-builts, which include all of the above details along with this certification sheet. An example of a suitable DEB as-built is attached.

**Note:** As-builts are not approved by Waikato Regional Council. Responsibility for construction of the structures and accuracy of the as-builts rests with the certifying agent. This list is not exhaustive and should be used to highlight some key “Erosion and Sediment Control Guidelines for Soil Disturbing Activities” requirements.

## Example: Scaled drawing as built - Decanting Earth Bund

Catchment area \_\_\_\_\_

Total storage volume \_\_\_\_\_

Dead storage volume \_\_\_\_\_

Live storage volume \_\_\_\_\_

Minimum bund height \_\_\_\_\_

Emergency spillway width \_\_\_\_\_

**Note:** where the as built information differs from the approved ESCP or Waikato Regional Council guidelines, data supporting its compliance is to be provided.

As-Builts are not approved by Waikato Regional Council. Responsibility for construction of the structures and accuracy of the As-Builts rests with the certifying agent. This list is not exhaustive and should only be used to highlight some of the key requirements.

### 40mm decant with upstand for decanting earth bund.

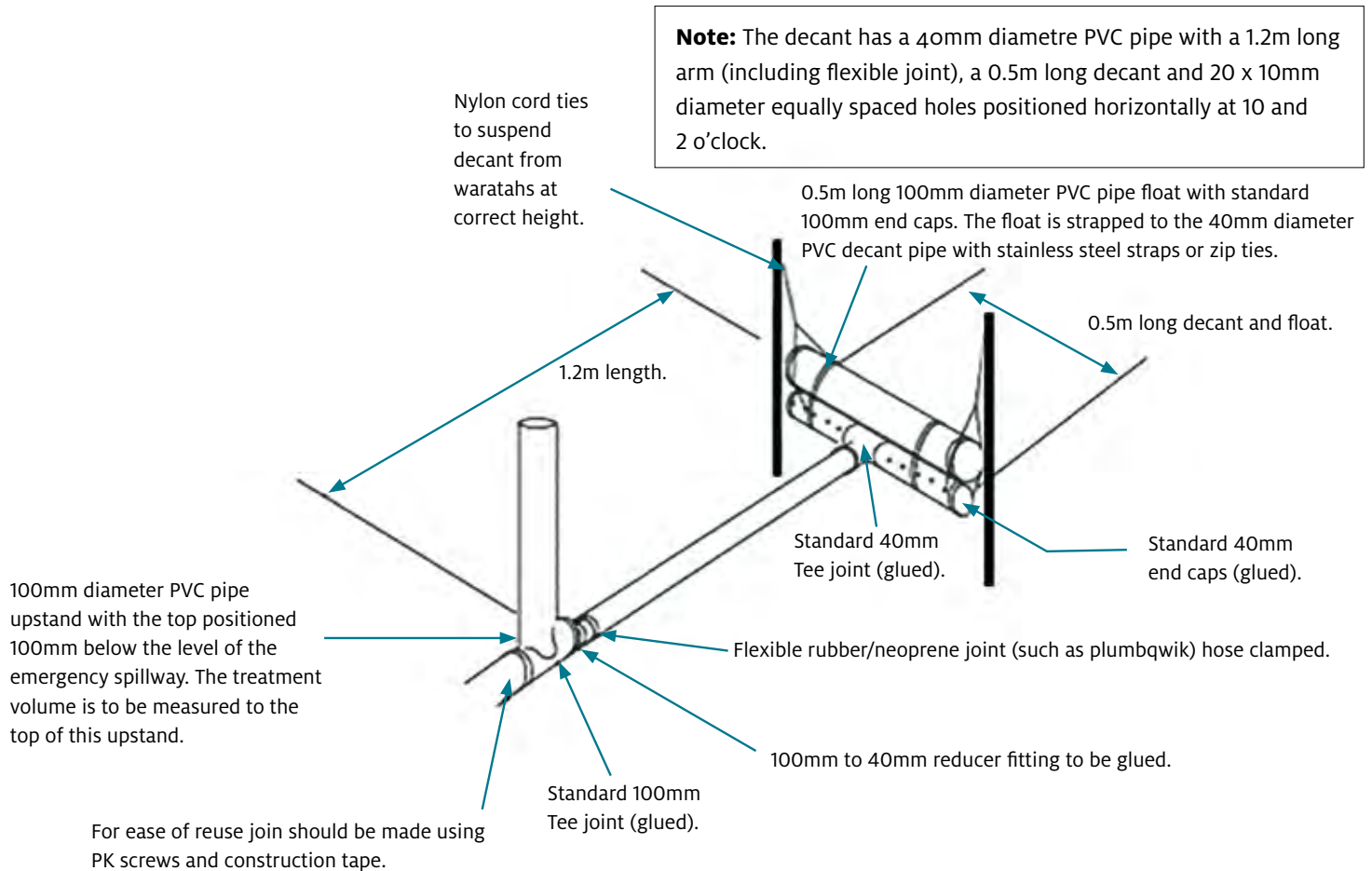

# Diversion bund/channel As-built Certification Sheet

**Diversion Name/number:** \_\_\_\_\_

Contributing catchment area (m <sup>2</sup> )	_____	
Maximum gradient in diversion contributing catchment (%)	_____	
Maximum gradient of bund/channel (%)	_____	
Bunds adequately compacted and stabilised/ Method of compaction	Y <input type="checkbox"/>	N <input type="checkbox"/>
Armouring required?	Y <input type="checkbox"/> N <input type="checkbox"/>	Type: _____
Diversion able to convey the 20% AEP event with 300mm freeboard?	Y <input type="checkbox"/>	N <input type="checkbox"/>
Discharge point stabilised?	Y <input type="checkbox"/>	N <input type="checkbox"/>
Flows directed to treatment device for dirty water diversion and offsite for cleanwater diversion?	Y <input type="checkbox"/>	N <input type="checkbox"/>
Bund a minimum of 550mm high & 2m wide	Y <input type="checkbox"/>	N <input type="checkbox"/>
Diversion inlet 3:1 or flatter?	Y <input type="checkbox"/>	N <input type="checkbox"/>
Diversion embankment 2:1 or flatter	Y <input type="checkbox"/>	N <input type="checkbox"/>
Diversion channel width 1m minimum	Y <input type="checkbox"/>	N <input type="checkbox"/>
Waikato Regional Council approved variations to device (please list)	_____	

Please sign below to confirm that the information in this sheet is accurate and the device identified on this sheet has been constructed in accordance with the Waikato Regional Council approved Erosion & Sediment Control Plan for the site and the "Erosion and Sediment Control Guidelines for Soil Disturbing Activities", January 2009 document or Waikato Regional Council approved variations.

Suitably Qualified Person (Name and company): \_\_\_\_\_

Signed and Dated: \_\_\_\_\_

Please provide surveyed drawings of as-builts, which include all of the above details along with this certification sheet. An example of a suitable diversion bund/channel as-built is attached.

**Note:** As-builts are not approved by Waikato Regional Council. Responsibility for construction of the structures and accuracy of the as-builts rests with the certifying agent. This list is not exhaustive and should be used to highlight some key "Erosion and Sediment Control Guidelines for Soil Disturbing Activities" requirements.

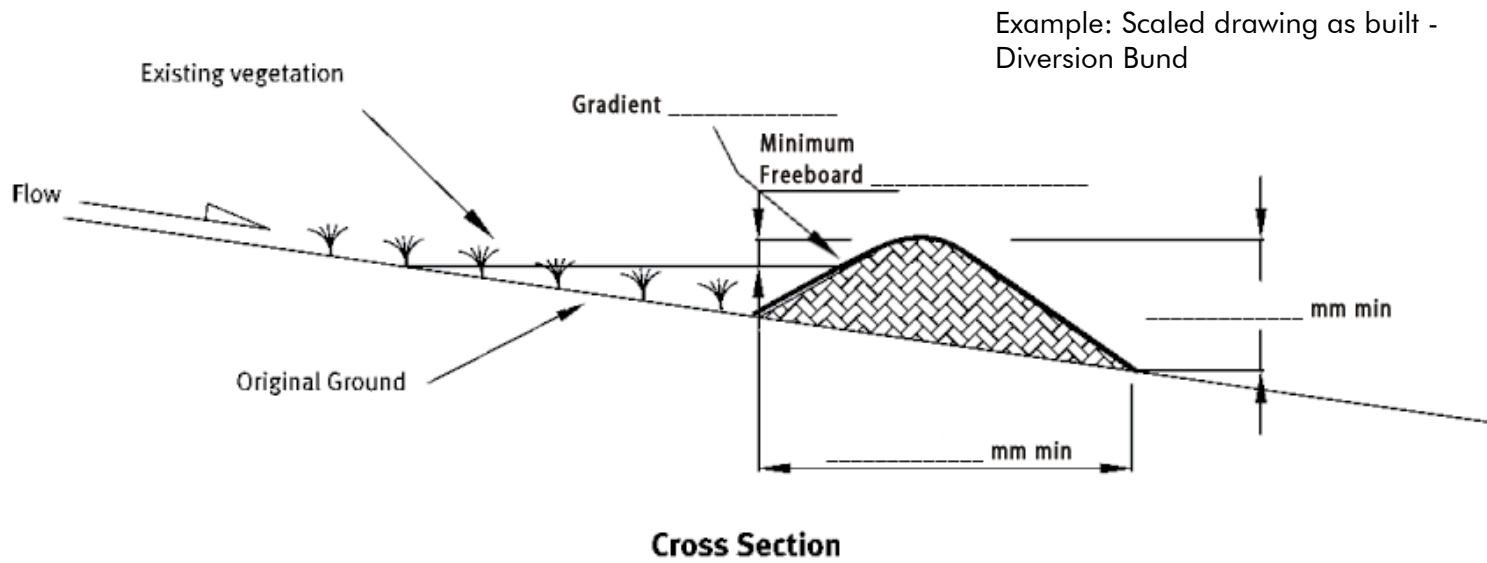

Catchment area \_\_\_\_\_  
 20% AEP event peak flow \_\_\_\_\_  
 Diversion capacity \_\_\_\_\_

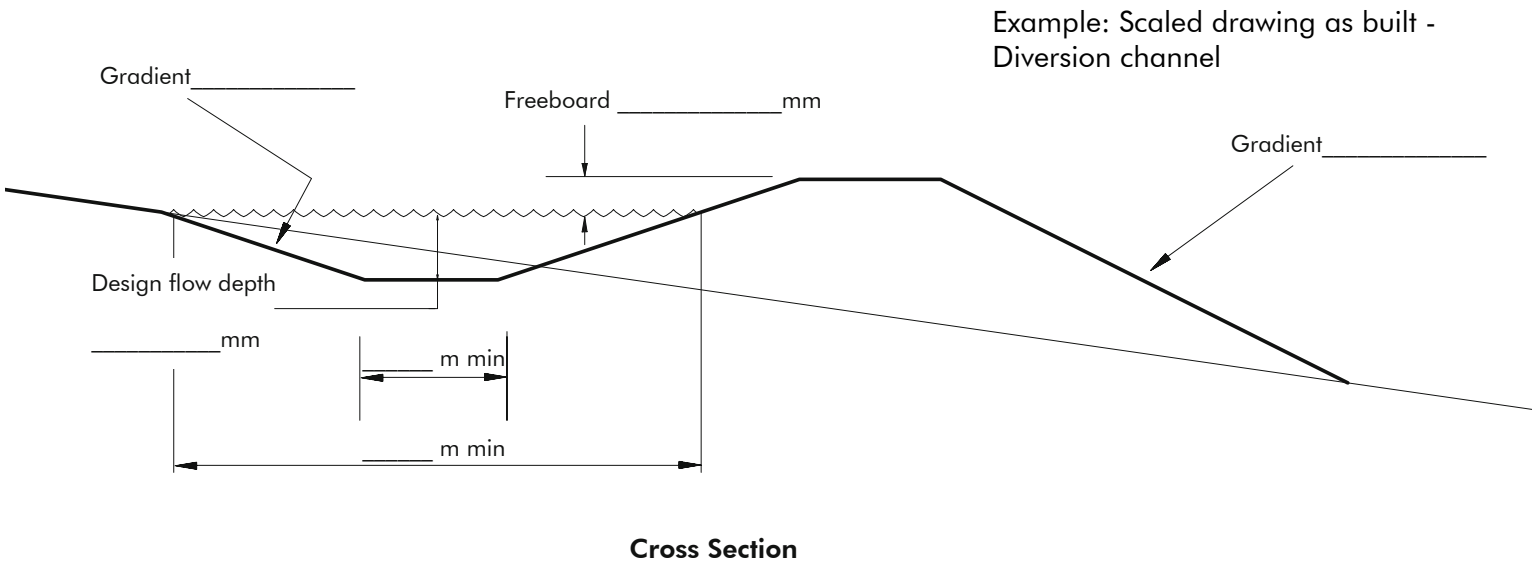

**Note:** where the as built information differs from the approved ESCP or Waikato Regional Council guidelines, data supporting its compliance is to be provided.

As-Built are not approved by Waikato Regional Council. Responsibility for construction of the structures and accuracy of the As-Built rests with the certifying agent. This list is not exhaustive and should only be used to highlight some of the key requirements.

# Sediment retention pond (SRP) As-built Certification Sheet

SRP name/number: \_\_\_\_\_

Contributing catchment area: (m <sup>2</sup> )		
Dead storage volume and depth	Volume (m <sup>3</sup> )	Height
Live storage volume and depth	Volume (m <sup>3</sup> )	Height
SRP dimensions set at SRP base	Length	Width
SRP dimensions at primary spillway height	Length	Width
Primary spillway diameter	mm	
Length to width ratio:		
Inlet batter 3:1	Y <input type="checkbox"/>	N <input type="checkbox"/>
Embankments adequately compacted/method of compaction		
Emergency spillway width and depth	Width	Depth
Emergency spillway able to pass 100 year event	Y <input type="checkbox"/>	N <input type="checkbox"/>
Emergency spillway stabilisation type		
Discharge point stabilised?	Y <input type="checkbox"/>	N <input type="checkbox"/>
Outlet pipe diameter		
Anti-seep collars installed	Y <input type="checkbox"/>	N <input type="checkbox"/>
Freeboard between primary & emergency spillway?	Y <input type="checkbox"/>	N <input type="checkbox"/>
Number of floating decants		
Weighted manhole riser	Y <input type="checkbox"/>	N <input type="checkbox"/>
Level spreader level?	Y <input type="checkbox"/>	N <input type="checkbox"/>
Level spreader full width of srp?	Y <input type="checkbox"/>	N <input type="checkbox"/>
Level spreader stabilisation type		
Level spreader haunched with concrete	Y <input type="checkbox"/>	N <input type="checkbox"/>
Waikato Regional Council approved variations to device (please list)		
Decant discharge rate	litres per second	

Please sign below to confirm that the as-built information in this sheet is accurate and the device identified on this sheet has been constructed in accordance with the Waikato Regional Council approved Erosion & Sediment Control Plan for the site and the "Erosion and Sediment Control Guidelines for Soil Disturbing Activities", January 2009 document or Waikato Regional Council approved variations.

Suitably qualified person (name and company): \_\_\_\_\_

Signed and dated: \_\_\_\_\_

Please provide surveyed drawings of as-builts, which include all of the above details along with this certification sheet. An example of a suitable SRP as-built is attached.

**Note:** As-builts are not approved by Waikato Regional Council. Responsibility for construction of the structures and accuracy of the as-builts rests with the certifying agent. This list is not exhaustive and should be used to highlight some key "Erosion and Sediment Control Guidelines for Soil Disturbing Activities" requirements.

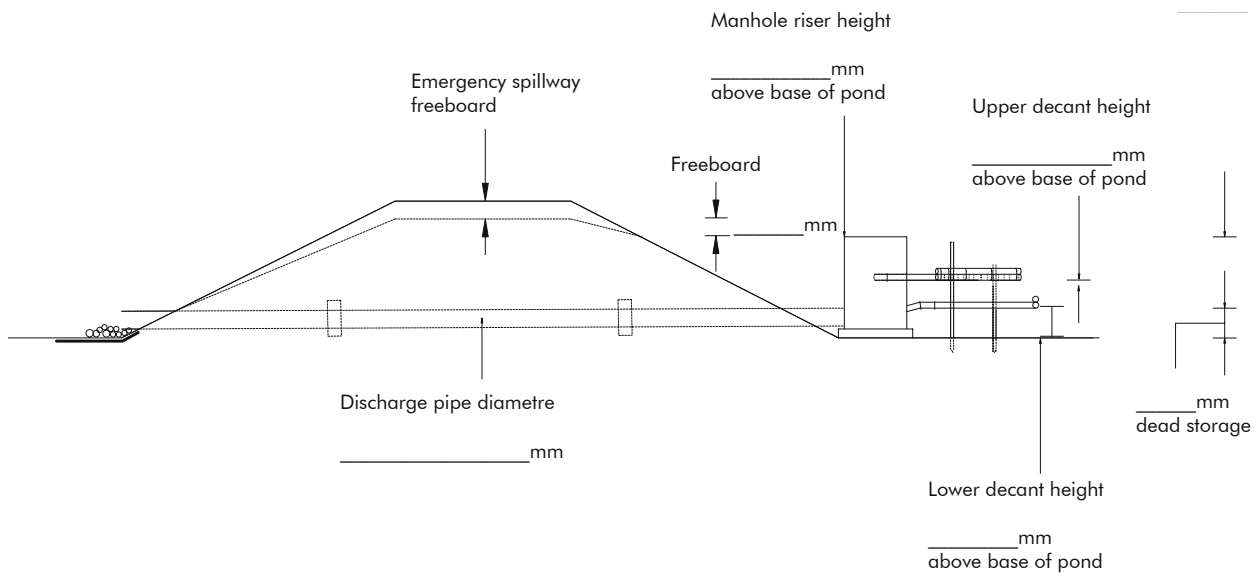

**CROSS SECTION**

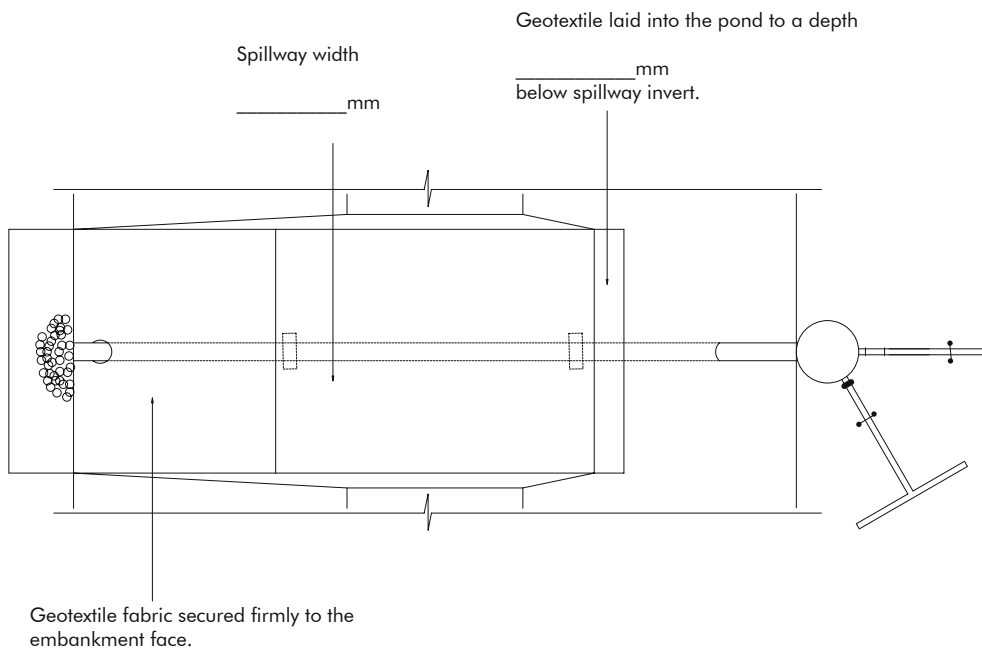

**PLAN**

Example: Scaled drawing as built - Sediment retention pond

SRP No/Name \_\_\_\_\_  
 Catchment area \_\_\_\_\_  
 As built volume \_\_\_\_\_  
 Decant rate \_\_\_\_\_  
 forebay volume \_\_\_\_\_

**Note:** where the as built information differs from the approved ESCP or Waikato Regional Council guidelines, data supporting its compliance is to be provided.

As-Builts are not approved by Waikato Regional Council. Responsibility for construction of the structures and accuracy of the As-Builts rests with the certifying agent. This list is not exhaustive and should only be used to highlight some of the key requirements.

# Silt/Super silt fence (SF) As-built Certification Sheet

Silt/super silt fence name/number: \_\_\_\_\_

Contributing catchment area (m <sup>2</sup> )		
Spacing between support posts (m)		
Support wire installed	Y <input type="checkbox"/>	N <input type="checkbox"/>
Trenched into ground minimum of 200mm	Y <input type="checkbox"/>	N <input type="checkbox"/>
Joins sealed	Y <input type="checkbox"/>	N <input type="checkbox"/>
Spacing between returns (m)	Y <input type="checkbox"/>	N <input type="checkbox"/>
Length of returns (m)		
Silt fence intercepting only sheet flows	Y <input type="checkbox"/>	N <input type="checkbox"/>
Chain mesh/netting backing (super sf)	Y <input type="checkbox"/>	N <input type="checkbox"/>
Double layer of fabric (super sf)	Y <input type="checkbox"/>	N <input type="checkbox"/>
Waikato Regional Council approved variations to device (please list)		

Please sign below to confirm that the information in this sheet is accurate and the device identified on this sheet has been constructed in accordance with the Waikato Regional Council approved Erosion & Sediment Control Plan for the site and the "Erosion and Sediment Control Guidelines for Soil Disturbing Activities", January 2009 document or Waikato Regional Council approved variations.

Suitably qualified person (name and company) \_\_\_\_\_

Signed and dated: \_\_\_\_\_

Please provide drawings of as-builts, which include all of the above details along with this certification sheet. An example of a suitable silt fence/super silt fence as-built is overleaf.

**Note:** As-builts are not approved by Waikato Regional Council. Responsibility for construction of the structures and accuracy of the as-builts rests with the certifying agent. This list is not exhaustive and should be used to highlight some key "Erosion and Sediment Control Guidelines for Soil Disturbing Activities" requirements.

Example: Scaled drawing as built -  
Super silt fence

Standard detail  
for Super Silt Fence

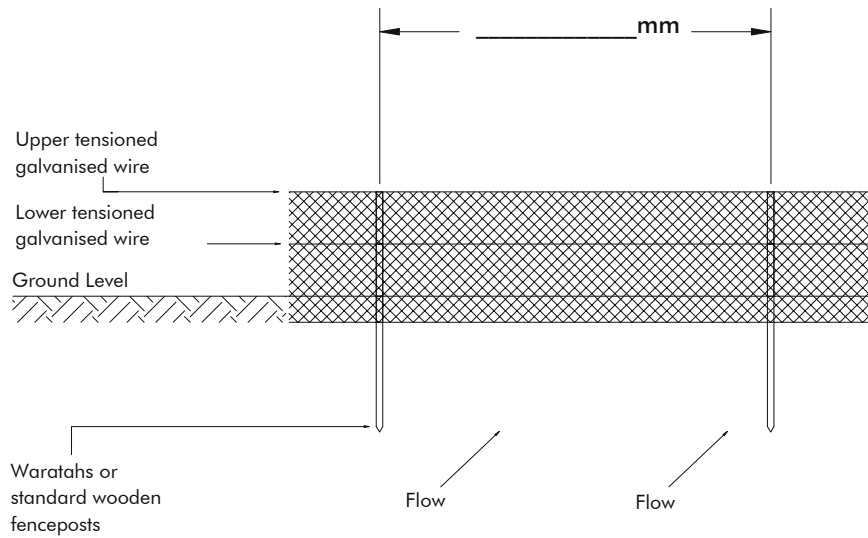

ELEVATION

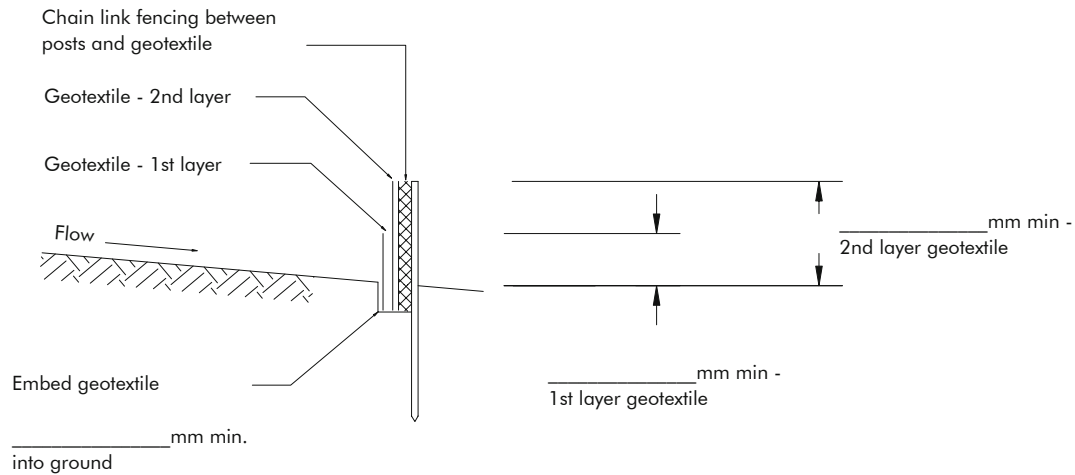

CROSS SECTION

**Note:** where the as built information differs from the approved ESCP or Waikato Regional Council guidelines, data supporting its compliance is to be provided.

As-Builts are not approved by Waikato Regional Council. Responsibility for construction of the structures and accuracy of the As-Builts rests with the certifying agent. This list is not exhaustive and should only be used to highlight some of the key requirements.