

Seven Oaks Kinloch Limited

30 Okaia Drive, Kinloch

Engineering Services Report – Balance Land

220225
10 November 2023

Seven Oaks Kinloch Limited

30 Okaia Drive, Kinloch

Engineering Services Report – Balance Land

Prepared by:



Thomas Brand
Regional Manager; Chartered Professional Engineer
BSc (Civil), CPEng, CMEngNZ, IntPE (NZ)

Reviewed by:



Lourdes Uriarte
Senior Civil Engineer
BEng Tech (Civil)

Date: 10 November 2023
Reference: 220225
Status: FINAL
Revision: NA
Previous Revision Date: NA

This document is the property of Cheal Consultants Limited. Any unauthorised employment or reproduction, in full or part is forbidden.

This document has been prepared for a specific purpose for the above client and shall not be used for any other unauthorised purpose. Cheal Consultants Limited does not acknowledge any duty of care or responsibility to any other party.

© Cheal Consultants Limited

TABLE OF CONTENTS

1. SCOPE	4
2. SITE DESCRIPTION	4
3. GEOTECHNICAL CONTEXT OF THE SITE	5
4. EARTHWORKS	6
4.1 Proposed Earthworks Philosophy	6
4.2 Preliminary Earthworks Volumes and Depths	8
4.3 Erosion and Sediment Control	14
5. STORMWATER	15
5.1 Primary Disposal System	15
5.2 Secondary Overland Flow	15
5.3 Overland Flow from Adjacent Property	16
5.4 Stormwater Volumes and Treatment for Specific Catchments	17
5.5 Permitted Activity Compliance	18
6. WASTEWATER	19
6.1 Wastewater Reticulation	19
6.2 Lisland Drive Pump Station Storage Upgrade	19
6.3 Kinloch Treatment Scheme Capacity	20
6.4 Sewer Pressure Individual Pump Station	21
6.5 Kahikatea Drive Sewer Extension	22
7. ROADING	22
7.1 Public Roads	22
8. WATER SUPPLY SERVICING	25
8.1 Water Supply Reticulation	25
8.2 Kinloch Water Supply Capacity	25
9. POWER AND TELECOM SERVICING	26
10. DISCLAIMER	26

Appendices –

1. Cheal Scheme Plan 220225-SC001
2. Cheal Concept Drawings for Earthworks, Roading and Services
3. Lisland Pump Station Storage Upgrade Calculations, Proposed Sketch Layout and Background
4. Taupō District Council Kinloch Future Development Map
5. Upper Catchments and Preliminary Swale Sizing
6. Catchments included in Stage 2 Stormwater Pond

1. SCOPE

Cheal has been engaged by Seven Oaks Kinloch Limited to obtain a staged subdivision consent for the balance of Seven Oaks land to create a total of 100 lots. The land is zoned partly as Kinloch residential and part Kinloch low density residential. Given the proposed lot sizes, the subdivision consent application will be a non-complying activity. Land use consent will also be required from Taupō District Council to consent bulk and location of future dwellings. This Engineering Services Report has been prepared in support of the consent application. In addition, a Landscape and Visual Assessment (LVA) and planting plan as well as a traffic assessment will be prepared by others.

This Engineering Services Report serves to outline preliminary design recommendations and drawings for earthworks, roading, stormwater management, water reticulation, wastewater reticulation, as well as power and telecommunications network availability.

Seven Oaks Stages 1 to 8 and the Terraces (Stages 1 and 2) are either fully constructed or underway to varying degrees at the time of writing this report.

2. SITE DESCRIPTION

The Seven Oaks balance land is located at the end of the current Okaia Drive to the north of the previously designed and constructed Stages 1 through 8. The balance land development will entail extension of Okaia Drive and will serve as a connection with existing Kahikatea Drive. The site area generally falls gently from north to south and is currently used for grazing. No significant vegetation or major flow paths are contained within the site which is bordered by additional farming to the north and Department of Conservation (DoC) land to the west and southeast. The northern block of land, known as The Terraces, is currently under construction – starting with the extension of Kahikatea Drive and Stages 1 and 2.

Given the Terraces subdivision generally slopes down into the balance land site, consideration has been given to diverting or transferring existing offsite flows around or through the development, in conjunction with a separate engineering services report prepared for The Terraces block.

The development surrounds two existing 1-hectare blocks, one of which contains a house and various outbuildings. Another residence lies immediately to the north of the proposed Kahikatea Drive extension. Again, careful consideration will be required for maintaining access to these properties, addressing Stormwater runoff and managing earthworks so as to limit impacts on these properties.

To be read in conjunction with Scheme Plan 220225-SC001 found in Appendix 1.



Figure 1 – Balance Land Location (Light Purple Area)

3. GEOTECHNICAL CONTEXT OF THE SITE

Although there has not been a specific geotechnical investigation completed for the site, the extensive earthworks completed within Stages 1 to 8 confirms that the general site area is Pumice (Orthic Pumice – Taupō Pumice Alluvium) which is typical soil for the Taupō Volcanic Zone. Pumice soils are free draining and can contain a mix of fine grained to coarse grained material. Local engineers and contractors are familiar with these soils, which are highly suitable for supporting structures and roadways. Care must be taken during construction as these soils can be highly erodible but successful methodologies have been developed in the area to control runoff and potential sediment runoff. It is also known now from previous stages of Seven Oaks that the upper soils have a lower permeability than is typical for pumice soils. Allowance will be made for this during detailed design and to ensure that soakage ponds can be adequately drained.

The Taupō District Plan does not show any fault lines near the property.

4. EARTHWORKS

4.1 Proposed Earthworks Philosophy

Earthworks are proposed over the balance land to generally shape the land and smooth out the various hummocks and hollows which feature over the balance land area in an effort to minimise earthworks for the future lot owners. However, given the general contour of the area is not steep, formation of individual building platforms is not proposed and some level of earthworks may be required for individual lots. Preliminary earthworks drawings found in Appendix 2 show existing and proposed contours as well as cut and fill depths. Earthworks will likely be completed in a staged approach which will be determined and detailed as each stage progresses, with review and approval from Taupō District Council completed at that time. To achieve a balance of earthworks on the site, neighbouring property owned by the applicant and yet undeveloped (such as Stage 8 and the Terraces) can be used to make up any shortage of fill material.

The design philosophy seeks to minimise earthworks and create a near cut to fill balance to avoid any import or export of soil material. No retaining walls are envisaged at this time, this will be confirmed during detailed design or individual lot owners may choose to construct retaining walls to maximise flat area within their lot.

All proposed earthworks within the Balance Land area will meet the requirements of the Waikato Regional Council (WRC) Permitted Activity (PA) status rule 5.1.4.11 (Soil Disturbance, Roding and Tracking and Vegetation Clearance) of the Regional Plan. Therefore, consent from WRC will not be required and the below commentary shows how compliance is or will be achieved for the various conditions outlined in Rule 5.1.5.

- a) *Organic material shall not be place in fill where its subsequent decomposition will lead to land instability.*
This condition will be met through appropriate construction management.
- b) *Erosion/sediment controls shall be installed and maintained on all earthworks during and on completion of the works to avoid the adverse effects of sediment on water bodies.*
This condition will be met through detailed design and construction management.
- c) *Cut-offs or culverts shall be designed and installed to prevent scour, gullyng or other erosion.*
This condition will be met through detailed design.
- d) *Any erosion of instability of the coastal environment, or the beds of rivers and lakes or wetlands shall be avoided or remedied if it does occur.*
Not applicable.
- e) *The activity shall not result in neighbouring land becoming subject to flooding.*
This condition will be met through detailed design of the finished ground levels and provision for overland flows paths of neighbouring land through the proposed site where required.

- f) All disturbed vegetation, soil or debris shall be deposited or contained to prevent the movement of disturbed matter so that it does not result in:
- i. The diversion, damming or blockage of any river or stream, or
 - ii. The passage of fish being impeded, or
 - iii. The destruction of any habitat in a water body or coastal water, or
 - iv. Flooding or erosion.

This condition will be met through detailed design and construction management.

- g) The activity shall not disturb any archaeological site or waahi tapu as identified at the date of notification of this Plan, in any district plan, in the New Zealand Archaeological Association's Site Recording Scheme, or by the Historic Places Trust except where Historic Places Trust approval has been obtained.

Not applicable in terms of known sites but will be controlled through construction management and appropriate Accidental Discovery protocols implemented in the event of discovery of such a site during construction.

- h) The concentration of suspended solids in any point source discharge arising from the activity shall comply with the suspended solids standards as set out in Method 3.2.4.6. This condition applies only to permitted activity rules and excludes any non-point source discharges from roading, tracking and vegetation clearance activities (refer condition o) below).

This condition will be met through appropriate erosion and sediment control measures employed during construction as per previous Stages.

- i) Any discharge of contaminants into air arising from the activity shall comply with the permitted activity conditions in Section 6.1.8 except where the matters addressed in Section 6.1.8 are already addressed by conditions on resource consents for the site.

This condition will be met through appropriate construction management.

- j) In the event of any waahi tapu that is not subject to g) above being identified by the Waikato Regional Council to the person undertaking the activity, the activity shall cease insofar as it may affect the waahi tapu. The activity shall not be recommenced without the approval of the Waikato Regional Council.

This condition will be met through appropriate construction management.

- k) No storage or mixing of fuels, oils, or agrichemicals shall be undertaken in areas where deliberate or inadvertent discharge is likely to enter any permanent natural surface water body.

This condition will be met through appropriate construction management.

- l) All vegetation that is being felled within five metres of a perennial water body shall be felled away from the water body, except edge vegetation, or vegetation leaning over a water body which, if necessary, may be felled in accordance with safety practices.

No applicable as no such water bodies exist on site.

- m) All exposed areas of soil resulting from the activity shall be stabilised against erosion by vegetative cover or other methods as soon as practical following completion of the activity and no later than six to twelve months from the date of disturbance to avoid the adverse effects of sediment on water bodies.

This condition will be met through appropriate construction management.

- n) *The activity shall not be located within 20 metres of a Significant Geothermal Feature.*
Not applicable.
- o) *The concentration of suspended solids in any non-point discharges from roading, tracking and vegetation clearance activities shall meet the following standards;*
- i. *The activity or discharge shall not result in any of the following receiving water standards being breached:*
 - ii. *In Waikato Region Surface class waters – 100 grams per cubic metre suspended solids concentration*
 - iii. *In Indigenous Fisheries and Fish Habitat class waters – 80 grams per cubic metre suspended solids concentration*
 - iv. *In Trout Fisheries and Trout Spawning Habitat class waters – 25 grams per cubic metre suspended solids concentration*
 - v. *In Contact Recreation class waters – black disc horizontal visibility greater than 1.6 metres*
 - vi. *In Natural State class waters – the activity or discharge shall not increase the concentration of suspended solids in the receiving water by more than 10 percent*

Standard a) shall apply, except where the suspended solids concentration or black disc horizontal visibility in the receiving water is greater than the standards specified, at the time and location of discharge or of undertaking the activity. Then there shall not be any increase (i.e. further deterioration) in the receiving water suspended solids concentration or black disc horizontal visibility of more than 20% as a result of the activity or discharge.

The point at which compliance with this standard shall be measured is after reasonable mixing has occurred which in any instance does not exceed 200 metres from the point of discharge.
This condition will be met through appropriate construction management.

- p) *Soil disturbance associated with the construction of a road or track within 20 metres of a culvert or bridge provided for in Rules 4.2.8.1, 4.2.8.2, 4.2.9.1, 4.2.9.2, and 4.2.9.3;*
- i. *Shall not occur adjacent to Significant Indigenous Fisheries and Fish Habitat Class waters during August to December inclusive and Significant Trout Fisheries and Trout Habitat class waters during May to September inclusive; and*
 - ii. *Shall be stabilised against erosion by vegetative cover or other methods as soon as practical following completion of the activity and no later than two months from the date of disturbance to avoid the adverse effects of sediment on water bodies; and*
 - iii. *The location of the proposed soil disturbance shall be notified to the Waikato Regional Council in writing at least 10 working days prior to commencing construction.*
- Not applicable.**

4.2 Preliminary Earthworks Volumes and Depths

Preliminary earthwork volumes proposed over the Balance Land area (all stages, including Kahikatea Drive) are approximately 83,000m³ of insitu cut and 48,700m³ of insitu fill. Allowing for using a compaction factor of 0.6 on the cut, this achieves a near balance for earthworks. The current cut and fill volumes represent preliminary bulk quantities only and does not account for road cut to subgrade works or cuts for overland flow swales. The maximum depth of cut is approximately 5m and fill around 6m at its deepest. However, these will be confirmed and refined during detailed design to achieve a balance cut to fill to prevent material to be transported on or off the site.

It is important to highlight that this development encompasses two different district zone areas. Kinloch Low Density Residential area to the north and Kinloch Residential to the southeast, as shown on the Scheme Plan 220225-SC001. Along the DoC boundary with the Kinloch low density residential zone, the District Plan setback requirement is 10m with no cut or fill greater than 0.5m. However, since this proposal is for a Kinloch Residential zone density a setback of 7.5m has been used to delineate restricted earthworks. This is consistent with the Kinloch residential performance standard and previous stages of Seven Oaks. Ground levels will not be altered at the boundary of any adjacent DoC Reserve area. Effort has been made to minimise earthworks greater than 0.5m within 7.5m of DoC Reserve area and 1.5m of other boundaries.

However, at certain locations the proposed earthworks do not meet these criteria. It should be clarified that at no time will cut or fill occur in DoC Reserve areas. Existing ground levels will be maintained to +/- 0.0m cut or fill.

The ground will be shaped sloping towards this development and away from DoC land. There are areas of the site where the District Plan requirement of a maximum 0.5m depth of cut or fill within 7.5m of the DoC Reserve will be exceeded and these are discussed below.

For cut and fill depth please refer to Earthworks Cut and Fill Plan 220225-SK203 where the green to blue shading represents fill and beige, orange, brown to dark red shading represents cut. Cut and fill depth shading are at 1.0m depth intervals to provide shading where restrictions are not met.

4.2.1 Lots 1 & 2

Within Lots 1 & 2 in Stage 13, the land in general falls south towards neighbouring DoC Reserve land. The existing land is undulating and traversed by a large depression running east to west on the lower Lot 1 and North of Lot 2, with the land in general falling south towards the DoC land. Lot 2 presents undulations of 1m cut and fill marginally extending into the 7.5m buffer line. Lot 1 is located adjacent to an existing gully to the east and mostly covered by rock outcrops formation. These outcrops and undulation of the land will be trimmed encroaching into the 7.5m setback east of the lot. These pockets of land extending into the DoC Reserve setback area (not into the DoC Reserve itself), to provide a suitable building platform for these lots, will require cut and fill depths of up to 2.5m on Lot 1 and +/- 1m on Lot 2 adjacent to the 7.5m buffer line. A batter will be created transitioning smoothly to +/- 0.5m to natural ground height as shown below, where beige/red represents cut and yellow/green is fill.

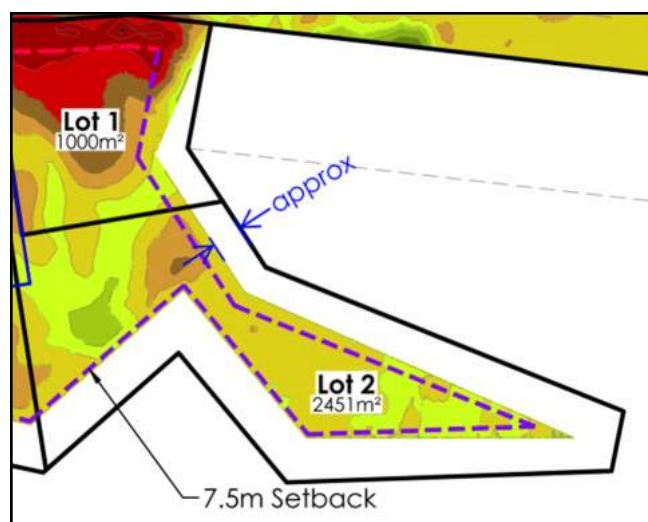

Figure 2 - Lots 1 and 2

4.2.2 Lot 14

The land to the west side along DoC Reserve is higher than the proposed lots' design. To provide well graded lots in this area, the high land will be cut and a batter constructed from the DoC Reserve land height towards the lot. This requires a cut and fill up to 0.5m in depth adjacent to the 7.5m buffer line and battering down height, as shown below, where the beige/brown represents cut and yellow/green represents fill.

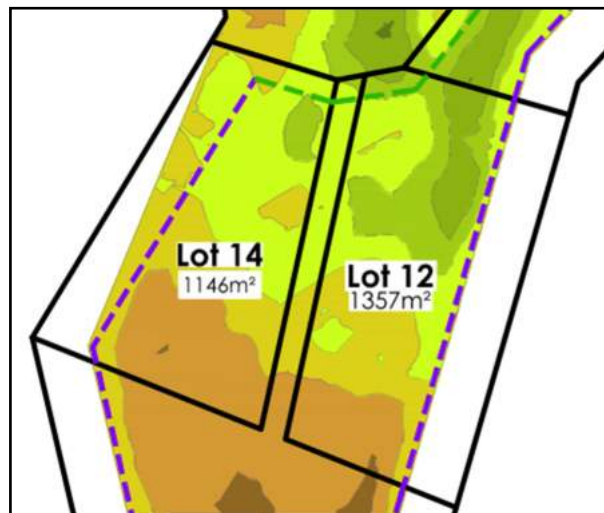

Figure 3 – Lot 14

4.2.3 Lots 15 to 17

Lots 15 to 17 share their western boundary with DoC Reserve. Undulating land follows an existing natural gully west on DoC Reserve. High spots protruding along the 7.5m setback will be cut down to meet the road allowing access to these sites and prevent private owners carrying out earthworks within the 7.5m zone adjacent to the DoC Reserve. Similarly, for areas with low levels, fill will be used to meet the proposed design. In order to supply well graded lots, a cut and fill of up to 1m depth in the adjacent 7.5m buffer zone with gentle battering down to meet existing ground is required.

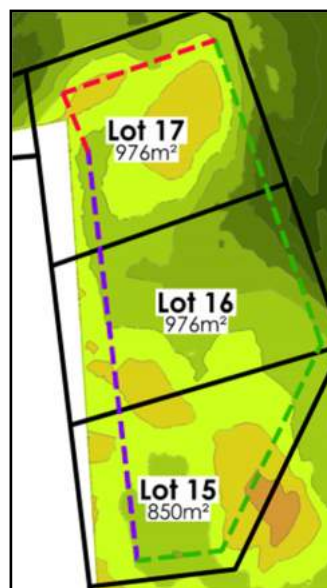

Figure 4 – Lots 15 to 17

4.2.4 Lots 61 to 70

The perimeter of these sites to the west is bordered by Department of Conservation Estate Land (DoC Reserve). Within these lots the land is relatively wide and open, with an undulating terrain and an overall gentle downhill gradient from north to south where small gullies fall towards DoC Reserve. High spots of land protruding along the 7.5m setback will be cut down to adequately merge the lots entrance accessing from Okaia Drive. Low gully pockets crossing the land will be filled to provide a general level area. Recontouring will allow to provide well graded lots with maximum 1m cut depths in the adjacent 7.5m buffer zone and similar maximum fill of 1m. The approximate setback of the proposed earthworks to the DoC Reserve in this area is approximately 4.5m from the common boundary line.

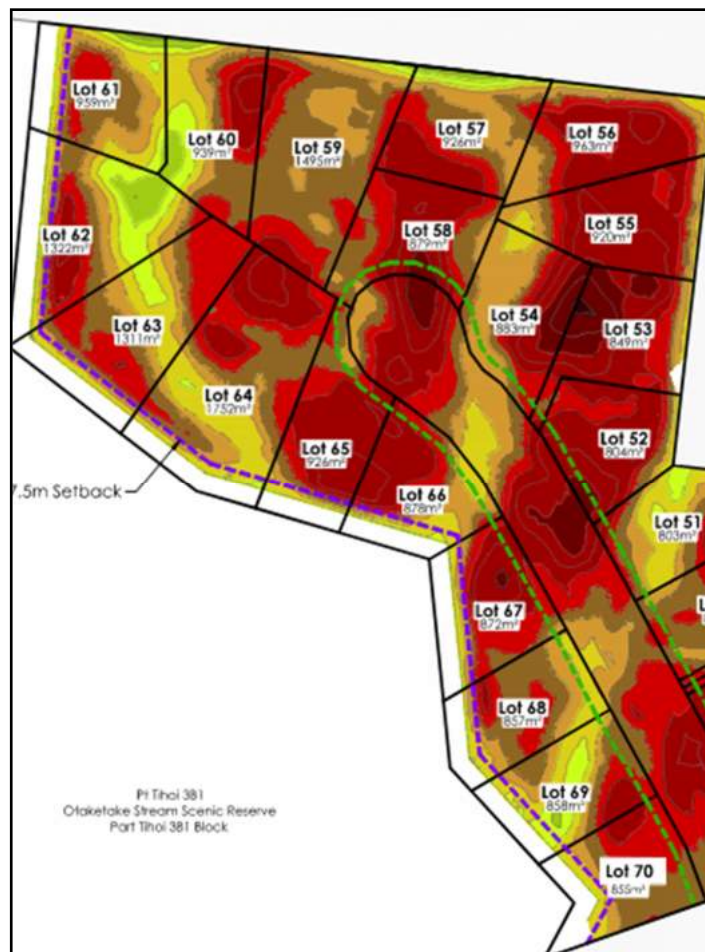

Figure 5 - Lots 61 to 70

4.2.5 Lot 73

Lot 73 sits on an existing 'storage pond' built as part of Seven Oaks Subdivision for erosion and sediment control. The pond location was selected to utilise the natural capabilities of untouched ground and minimise earthworks of future development. The surrounding areas will be cut to meet road geometry and provide suitable building platforms, however the area sits higher than its surrounding. To construct building platforms recontouring areas of cut and fill will extend beyond the 7.5m setback with a maximum fill of 1.5m at the 7.5m buffer line then battering down gently to meet natural ground at DoC Reserve, as shown in Figure 6 below, where green shading represents fill and beige/orange shading represents cut.

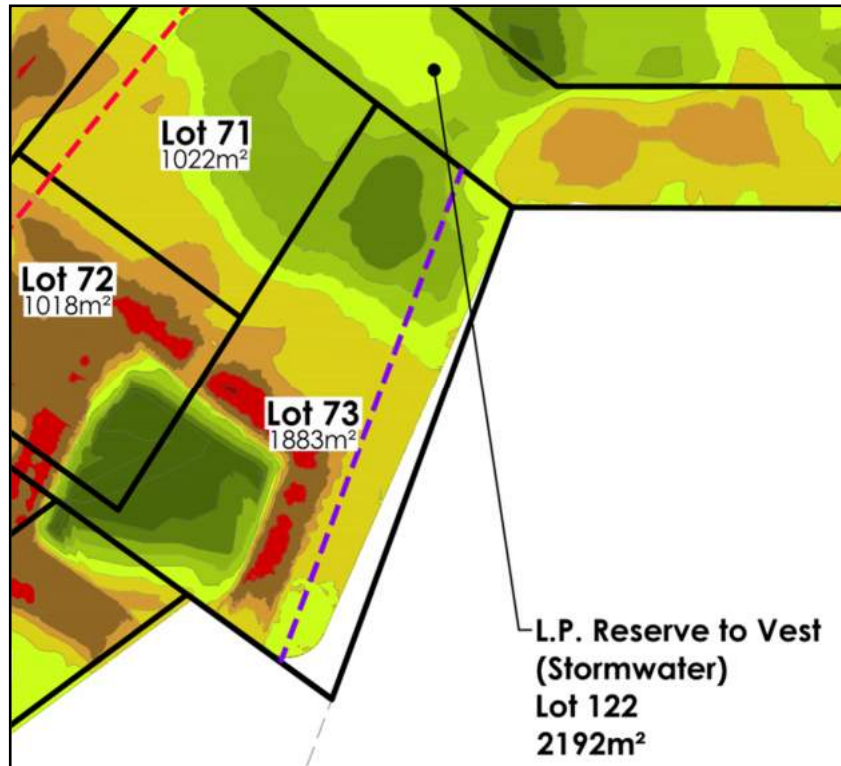

Figure 6 - Lot 73

4.2.6 Lot 76

Lot 76 are shaped around a natural spit of land surrounded by DoC Reserve. Lot 76 is northwest of the spit and presents formations higher than the surrounding area. To achieve building envelopes, a maximum cut of 1m at the 7.5m buffer line is required then battering down gently to meet natural ground at DoC Reserve, as shown in Figure 7 below, where green shading represents fill up to 0.5m and beige orange shading represents cut up to 1m.

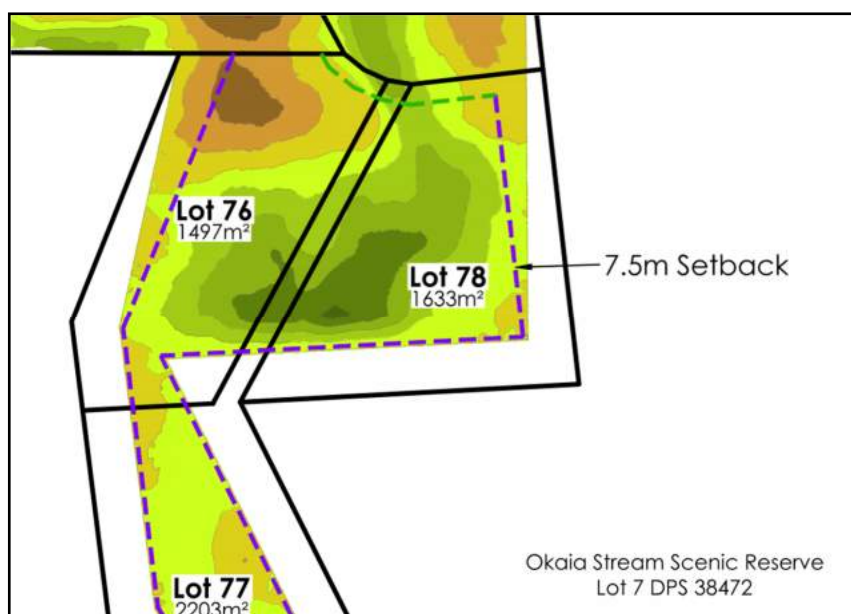

Figure 7 - Lot 76

4.2.7 Lot 78

A natural gully depression covers most of this site with the land falling southwest. The gully depression area extends within the 7.5m buffer zone. To form a suitable building platform requires fill to up to 1m at the 7.5m line battering down to natural existing ground at DoC Reserve, as shown in Figure 8 below, where green shading represents fill and beige shading represent cut up to 0.5m.

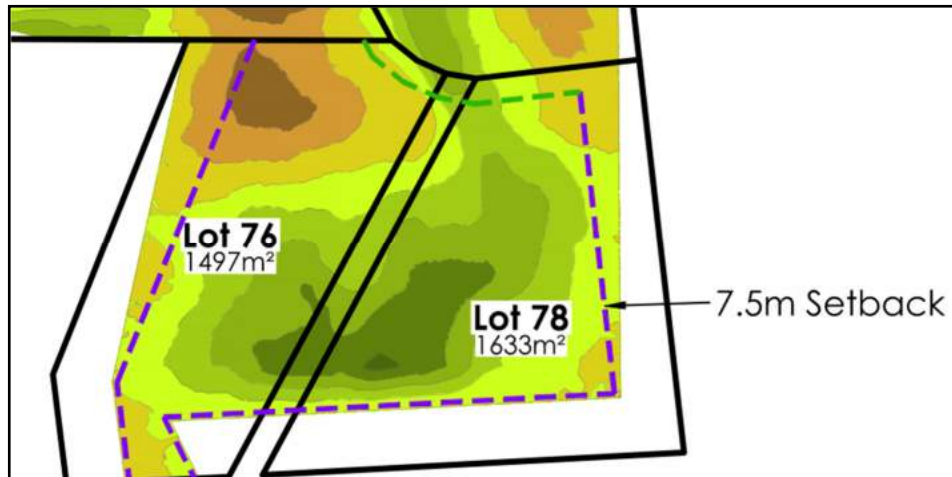

Figure 8 – Lot 78

4.2.8 Lot 79

The gully formation continues rolling down from Lot 80. Lot 79 land is shaped with a centred depression around 2m below the adjacent area and extending into the 7.5m setback to DoC Reserve. The intention is to provide earthworks suitable for future building to be constructed without need for additional cut or fill to be done by private owners within the 7.5m setbacks. A fill up to 2m depth away approximately 5m from DoC Reserve boundary is required to prevent ponding and erosion issues around these pockets of natural ground and the new compacted materials. To form a suitable building platform requires fill to up to 1.5 m at the 7.5m line battering down to natural existing ground at DoC Reserve, as shown in Figure 9 below, where beige shading represents cut and green shading fill.

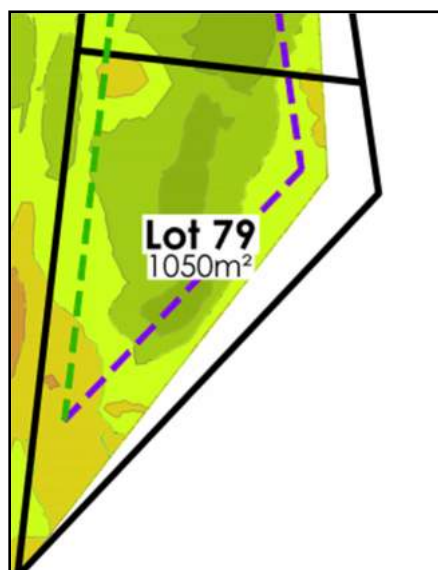

Figure 9 – Lot 79

4.2.9 Lot 80

Lot 80 is traversed by a low depressing gully running north to south towards DOC Reserve to the south east of this Lot. These undulations of the land require a maximum fill of 2m encroaching into the 7.5m buffer line then sloping down to meet existing ground. This requires fill beyond the 7.5m buffer line then a batter slope formed down to meet natural ground at DoC Reserve, as shown in Figure 10 below, where the dark green shading represents fill up to 2m deep and light green represents fill 0.5m within the 7.5m setback line.

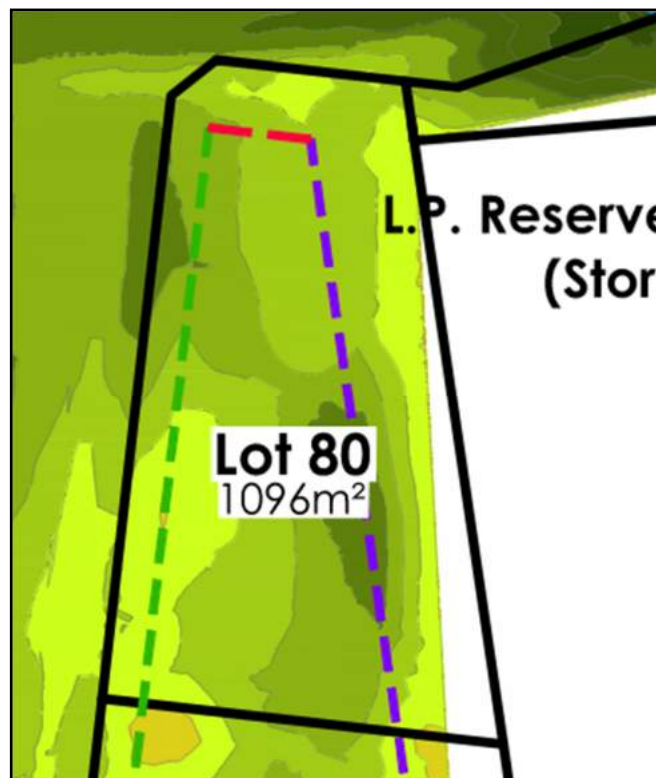

Figure 10 – Lot 80

In summary, preliminary earthworks modelling seeks to carry out earthworks comprising recontouring existing land to provide necessary shape to the site to accommodate future residential development while preventing unnecessary modification of the land in the 7.5m buffer zone with neighbouring DoC Reserve.

4.3 Erosion and Sediment Control

Various controls will be required during construction to manage erosion and prevent sediment discharge during the earthworks process onsite. These controls will likely consist of sediment retention ponds, decanting earth bunds, clean and dirty water diversion bunds, and silt fences. The design, installation, and management of these controls will be completed in accordance with the WRC guidelines. The design will also need to be approved by TDC during Engineering Approval stage. Monitoring of controls will be completed by TDC during the course of earthworks. Detailed design will be completed as required for the various stages of earthworks and a Construction Management Plan will be prepared and provided to Council prior to construction commencing.

It is acknowledged that the land surrounding the site is of significant environmental importance and is to be protected.

5. STORMWATER

Stormwater treatment and disposal for the balance land is proposed to follow similar methodologies used in previous stages of the Seven Oaks development. This will consist of catchpits and reticulation in the larger roads, with swales utilised for the shorter cul-de-sacs. Additionally, the balance land has an added consideration of upstream catchments which currently drain through the proposed development. Consequently, overland flow paths are proposed both through and around the site to allow for these flows.

Please refer to Appendix 2 for the proposed earthworks plan and conceptual services plans.

5.1 Primary Disposal System

As per the TDC Code of Practice, Stormwater runoff disposal from all dwellings and hardstand areas on each lot will be through individual soakholes or soakage pits on each lot, capable of dealing with a 10-year, 1 hour storm event.

The same storm event must be attenuated for all road corridors as well. Consequently, the roads are split into suitable catchment areas, with runoff collected via either swales or catchpits and directed to suitably sized soakage/attenuation ponds. These ponds will be sized for the 10-year, 1 hour storm event as per the TDC Code of Practice and will meet the permitted activity rules for Stormwater Discharge to Ground in the WRC Regional Plan.

Any proposed privately owned rights of way will utilise kerb and channel, with a catchpit draining to a concrete lined drilled soakhole for disposal of the 10-year, 1 hour storm volume.

The soakage ponds themselves will be placed in the Stormwater Reserves designated for that purpose. In line with the previous stages of development, these pond systems will consist of a smaller, low flow coarse sediment pond (first flush), with larger flows then directed to the primary detention pond via a large diameter pipe. A suitable overflow spillway (vegetated weir) will also be incorporated into the first flush pond for large flows. The base of the ponds will contain deep concrete lined drilled soakholes to allow the ponds to drain completely following a rain event. The Stormwater Reserves and associated ponds will be designed and situated such that a natural and attractive space is provided for walkways and recreational use as much as possible. The ponds shown on the current drawings are indicative only to ensure that enough space is available for the required volume. These will be refined during detailed design. Calculated storage volumes are 128m³ for the pond for Kahikatea Drive, 56m³ for the pond for Road 2 and 61m³ for pond for Road 3.

5.2 Secondary Overland Flow

For storm events greater than the 10-year, 1 hour event, or should the primary system experience blockages, secondary flow paths and emergency spillways are required to safely allow for passage of these flows. These flow paths will be provided within the road corridors and then through the Stormwater Reserves towards the existing flows paths below the site. Discharge points have been selected to align with existing flow paths into the adjacent downstream land. As with previous Stages 1 to 8, the design of the primary disposal system will be conservative to ensure that actual storage of runoff exceeds the 10-year, 1 hour requirement and that only extreme events will discharge flows

off site and only once significant treatment has occurred for initial flows through filtration and settlement within the ponds.

5.3 Overland Flow from Adjacent Property

As stated previously, there are a few existing flow paths entering the balance land site from the three existing properties to the north. Designated overland flow paths or specific Stormwater Reserves will be required to safely pass these flows through the balance land. These overland flow paths are indicated on the concept roading plan included in Appendix 2. Flow paths will consist of specifically designed and sized shallow swales or road corridors where available. Bunding will also be utilised along portions of the boundary to direct flows towards the low points for conveyance through or around the balance land.

Preliminary sizing of a swale for Ex-Catchments D and E has been completed to ensure allowance has been made within the affected lots for the overland flow paths as well as reasonable building area. Upper contributing catchments have been sized and flows calculated on a conservatively large basis and have been based upon 100 year flows from the upper catchments. Catchment sizing is shown in Figure 11 below.

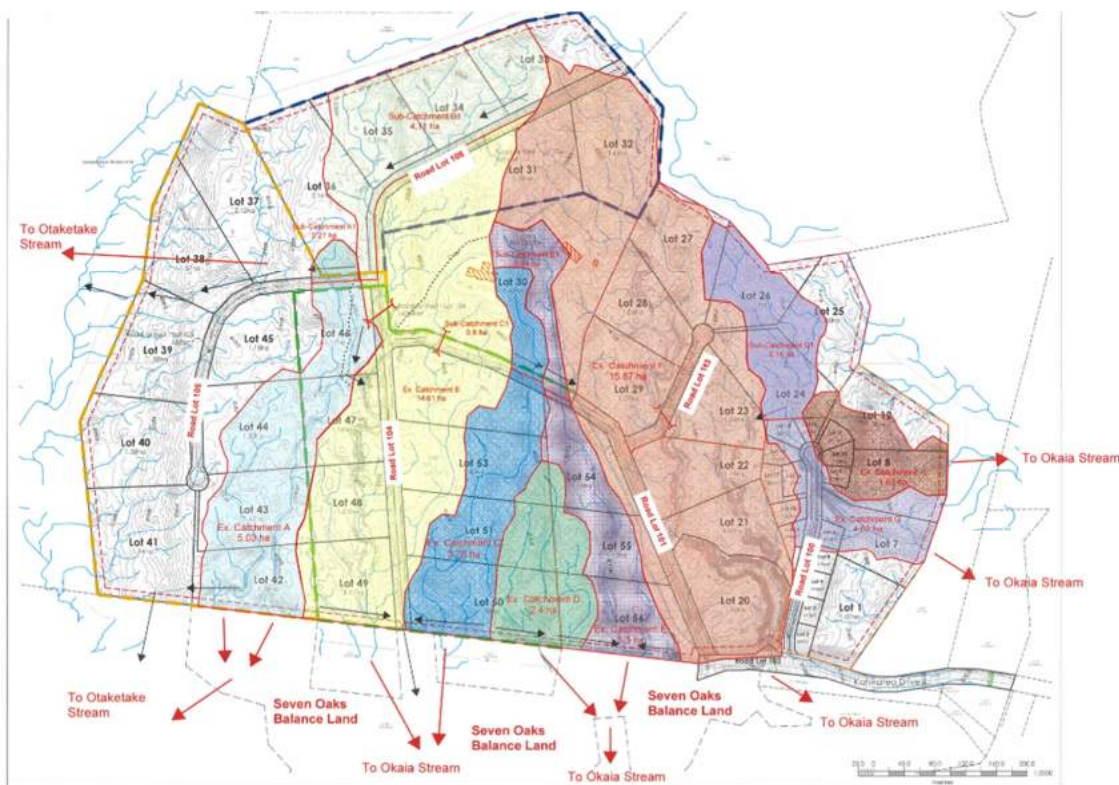

Figure 11 – Contributing Upper Catchment, The Terraces

There are just two locations of overland flow from The Terraces (Ex-Catchments B/C and Ex-Catchments D/E) that need to be collected and passed through the balance land property. All other flows from the Terraces (Ex-Catchments A, B1, and F) will be diverted within the Terraces and not pass through the balance land. WRC consent has already been granted for Earthworks and Diversions for the Terraces. Minor overland flow paths from existing Lots 1 and 2 will be directed as required with bunding and swales as indicated on the drawings.

Overland runoff flows from Ex-Catchments B and C of the Terraces will be collected via bunding and swales along the boundary within the Terraces block and directed towards and onto Road 01. These overland flow paths will then pass through the low point in Kahikatea Drive, into the Stormwater Reserve, and out into DoC land as per existing flow paths.

To avoid overland flows from smaller events from continually flowing over the berm and into Road 01, a secondary piping network is proposed within this road to carry these overland flows. This pipe will extend to the boundary of the Terraces as this will also convey minor flows from Ex-Catchment B. For larger events, this pipe capacity will be exceeded and flows will then be conveyed down Road 01 and into the Stormwater Reserve southeast of Kahikatea Drive.

Similarly, Ex-Catchments D and E overland flows will be collected via bunding and swales along the boundary within the Terraces block and directed to the designated Stormwater Reserve. This will contain a wide swale terminating in an inlet device, such as a manhole with scruffy dome or a wingwall, with a culvert outlet under Kahikatea Drive discharging to the DoC Reserve to the south. The flows from this upper catchment already flow to this same discharge point via natural flow paths. Catchment flows, preliminary swale sizing and culvert calculations are shown in Appendix 5.

5.4 Stormwater Volumes and Treatment for Specific Catchments

Area included in Stage 2 Pond

As presented in the previously issued (May 2020) Engineering Services Report for Seven Oaks Stages 2 – 9, the existing Stormwater pond completed in Stage 2 of Seven Oaks has already been designed to allow for a portion of Kahikatea Drive, the extension of Okaia Drive, as well as Road 1 up to the boundary of the adjacent property to the north – a total of 820m of 20m wide road. Consequently, these areas are all proposed to be connected with the existing reticulation in Okaia Drive and Kahikatea Drive.

Please refer to Appendix 6 for the catchment allowance for Stage 2 pond.

Kahikatea Drive – between Road Lot 102 (currently under construction) and high point at Lot 19

Due to limited space for a pond along this road, disposal of Stormwater in this section of road will be through soakage pits. In some cases, catchpits either side of road will be collected and disposed in a single soakage pit. In other cases, each catchpit will drain to its own soakage pit. This is dependent upon grades and space available within the road corridor. Preliminary soakage pit sizing has been completed for scoria filled pits generally 1.5m deep. There is sufficient space available for these pits, with design to be refined during detailed design.

Kahikatea Drive – between Lots 26 and 19

This section of Kahikatea Drive is proposed to be collected via catchpits and reticulation and discharge into Pond 1/1a in the Stormwater Reserve. A total combined storage volume of 128m³ is required to attenuate the 10-year, 1 hour storm event for this catchment.

Road 2

Runoff from this cul-de-sac is proposed to be collected via a swale on one side and kerb and channel on the other side with catchpits discharging through pipes into the swale. These flows will be discharged into Pond 2 in the Stormwater Reserve. A total storage volume of 56m³ is required to attenuate the 10-year, 1 hour storm event for this catchment.

Road 3

Runoff from this cul-de-sac is proposed to be collected via single cross fall roadway draining to a swale with a catchpit at the end of the cul-de-sac. These flows will be discharged into Pond 3 in the centre of the turn-around area, similar to that done for previous stages of Seven Oaks. A total storage volume of 61m³ is required to attenuate the 10-year, 1 hour storm event for this catchment.

5.5 Permitted Activity Compliance

All proposed Stormwater treatment/disposal will meet requirements of the WRC Permitted Activity rule 3.5.11.5 of the Regional Plan. Specifically, the rule requires compliance with the following:

- a) *The discharge shall not originate from a catchment that includes any high-risk facility or contaminated land unless there is an interceptor system in place.*
All runoff discharge originates from public roads or private residential lots and not from any high-risk facility.
- b) *The discharge shall be below a rate that would cause flooding outside the design discharge soakage area, except in rain events equivalent to the 10% Annual Exceedance Probability design storm or greater. Any exceedance shall go into designated overland flow paths.*
The proposed Stormwater treatment design captures and stores all runoff for storm events up to the 10%AEP event. These flows are discharged to ground. Overland flow from larger events will be directed to existing overland flow paths.
- c) *There shall not be any overland flow resulting in a discharge to surface water, except in rain events equivalent to the 10% Annual Exceedance Probability design storm or greater; then there shall be no adverse surface water effects as a result of the discharge.*
The proposed Stormwater treatment and disposal design captures and stores all runoff for storm events up to the 10% AEP event. These flows are all discharged to ground. In any case, overland flows are all directed to existing designated flow paths and not to any surface water.
- d) *Any erosion occurring as a result of the discharge shall be remedied as soon as practicable.*
Although measures will be implemented to ensure that no erosion occurs, the eventual Construction Management Plan will require this condition to be met.
- e) *The discharge shall not contain concentrations of hazardous substances that may cause significant adverse effects on aquatic life or the suitability of the water for human consumption after treatment.*
Given the nature of the development being residential, no significant hazardous substances are anticipated. Additionally, the Stormwater runoff will be treated through settlement ponds which are primarily discharged to ground which utilises filtration through the soil.

Therefore, Stormwater discharge to ground from the proposed subdivision will be fully compliant with the Permitted Activity Rules in the WRC Regional Plan.

6. WASTEWATER

Wastewater disposal for the balance land area can be primarily accomplished via gravity drainage. However, it is envisaged that 20 lots will require private pump stations, feeding into common rising mains as required and discharging into the gravity reticulation. The private pump stations will be provided by Seven Oaks when the future owners build on the section. The eventual owners then install, operate, and maintain the pump stations. This approach has been utilised through previous stages as well.

6.1 Wastewater Reticulation

Whether gravity or pumped, all wastewater flows from the balance land would discharge to the 150mm diameter gravity sewer main in Okaia Drive which eventuates at the Lisland Drive pump station. Including the existing properties in Okaia Drive, all Stages of Seven Oaks and the proposed balance land, the total proposed catchment for this sewer main is 247 lots.

Per Taupō District Council Code of Practice:

- Average dry weather flow per person 250 litres/day/person
- Diurnal peaking factor 2.3
- Wet Weather peaking factor 3.5
- People per dwelling 2.7

The resulting peak developed flow rate is therefore 17.421 litres/second. The existing 150mm gravity main is still sufficient to accommodate this peak flow rate.

6.2 Lisland Drive Pump Station Storage Upgrade

To accommodate the additional flows from the balance land, additional storage will need to be provided at the Lisland Drive pump station. The current pump station uses a 35m long, 1350mm diameter concrete pipe as a storage tank. There is currently one tank in place, but there is space on the site for an additional tank to be installed. As per the storage tank calculations in Appendix 3, there are 7 balance land lots already accounted for in the District Plan, 100 proposed balance land lots, 2 lots from Stage 2, 4 lots from Stage 8 and 20 balance land lots that will have their own pump stations with required storage. Consequently, total additional storage is required for 79 lots (100+2+4-7-20). To accommodate these additional lots, an additional 12-hour storage volume of 26.66m³ is required. Another tank will need to be installed consisting of approximately 8 sections 2.44m length each of 1350mm diameter concrete pipe. Please refer to Appendix 3 which provides a preliminary cross section and long section of the proposed new storage tank scheme, calculations for this additional proposed storage and existing pump station plans.

It is expected that existing pumps will be suitable but will run more frequently due to the additional proposed flows. However, if pump upgrades are necessary, this will be determined as part of the detailed design and upgrades implemented in the appropriate stage of the balance land development.

6.3 Kinloch Treatment Scheme Capacity

With regards to the overall capacity of the Kinloch wastewater treatment scheme, the information provided by Council previously indicates that there is sufficient capacity for wastewater for the proposed lots. Attached in Appendix 4 is the Kinloch Future Development Map provided by TDC which outlines how many lots have been accounted for in terms of water and wastewater infrastructure. Figure 12 below also indicates Council's plan for future properties.

Kinloch DC explanatory note
13 July 2021



2021 Planned growth compared to 2004 Kinloch Structure plan

2004 Structure plan ²		2021 update and LTP planned			
Current Kinloch (as at 2004)	610 lots (530 built on 80 vacant)	Current Kinloch As at 2020	1,368 lots (1,112 built on 256 vacant)		
Planned	Lots	Planned:	Lots	Water	Waste- water
Lisland Stage 3&4	160	Te Tuhi	44	y	n
GCD	289	Hunt Club	30	y	n
Loch Eagles	200	The Terraces	55	y	y
Commercial / infill / other	140	Seven Oaks	175	y	y
Future Areas	531	Oakdale Dr (Larches)	12	y	y
Total	1,930	Kinloch Rd Workshop	6	y	y
		Poplars Stage 2	12	y	y
		Kinloch Golf -future	108	y	y
		Kinloch Lodge (castle)	12	y	y
		Commercial / infill / other	96	y	y
		Total - planned growth	550	550	476
		Kinloch Total³	1,918	1,918	1,844

Figure 12 – TDC Planned Growth Table

From the attached development map in Appendix 4, 160 lots have been allowed for wastewater servicing for Seven Oaks Stages 1 – 9 and 30 additional lots have been allowed for the Balance Land. However, the Table in Figure 12 above indicates 175 lots. Given this discrepancy, a conservative approach has been taken and a total of 175 lots has been assumed to have been allowed for within the entire Seven Oaks subdivision area. Stages 1 to 8 account for a total of 147 lots with 100 lots being proposed for the Balance Land (includes the 9 lots previously shown as Stage 9), this results in a total of 247 lots, or 72 additional lots for Seven Oaks subdivision than originally planned.

However, the planned growth for infill lots in Kinloch also allows capacity for an additional 96 lots. Upon review of the existing Kinloch village residential zone, Cheal could only identify two standard residential properties greater than 2000m² which could theoretically be subdivided into a total of 9 lots – 7 additional lots. There are also 3 areas zoned as high density which could also theoretically

be subdivided. Using a minimum size of 420m² (similar to other high density lots in the area), an additional 17 infill lots could be generated in this high-density area. Based upon lot size only, this could potentially yield a total of 24 additional lots. In addition, from the Council table in Figure 12 above, it is noted that Council has assumed all 55 lots of the Terraces will be connected for water and wastewater supply. However, only 15 lots from the Terraces are intended to be connected to Council wastewater infrastructure.

Consequently, the 72 additional balance land lots, minus 40 lots from the Terraces, plus the 24 potential additional infill lots in Kinloch, results in 56 additional lots, which is within the 96 lots allowed for planned growth in the community.

Therefore, the infrastructure plan can accommodate the additional wastewater flows from the proposed balance land lots along with infill of current lots within Kinloch.

Refer to Appendix 1 for Conceptual Services Plan and Figure 13 below for the infill lot assessment.



Figure 13 – Potential Infill Lots for existing properties

6.4 Sewer Pressure Individual Pump Station

Due to the site topography, some lots are sited below the gravity reticulation and have been identified and marked on the Conceptual Services Layout Plans 220225-SK401 and SK402. Similar to Sherwood Way and Oakleaf Lane, these 20 lots will need individual pump stations as a solution to provide sewer connection to these lots. We are proposing installing individual pump stations E-one as used through Seven Oaks. They have a storage capacity for 24hours and will require a rising main which then will be connected to the gravity line. For those lots where the sewer public line is not at

the road frontage, a private satellite manhole will be constructed to provide individual sewer connections from these sites. The number of lots connected to a private manhole will be limited. A specific design for rising main pipe size and private manhole layout will be provided.

7. ROADING

The main access roads construction will be an extension of Okaia Drive and Kahikatea Drive, via the existing roundabout infrastructure. Provisions were made during the construction of the recently built Stages 1 and 2 of Seven Oaks subdivision for an intersection into the balance land area. Roads would generally comply with the TDC Code of Practice for Development Land. The narrower cul-de-sacs and private roads will be consistent with design and construction of the Seven Oaks subdivision, following TDC Code of Practice.

A detailed Integrated Transportation Assessment (ITA) was prepared by CKL to analyse the traffic and transportation effects of the proposed residential development. This forms part of the Resource Consent Application.

Engineering detailed design would be required for each stage to demonstrate there are no conflicts or if departures are proposed from the Code of Practice on the proposed infrastructures.

Low impact Stormwater features would be incorporated to the streetscape such as vegetated swales and landscaped Stormwater ponds to attenuate the flow of the development. This has successfully been used in the previous stages of the Seven Oaks Subdivision.

A trust relationship has built between DoC and the Client through an ongoing commitment of maintaining a high standard in respect to the maintenance and preservation of all natural reserve areas while construction works are being done. A 1.5m pool fence along DoC common boundary with private lot sections was constructed to clearly delineate DoC Reserve. This has enabled access via environmentally friendly modes to areas of conservation land and bike tracks (under approval of DoC). Community expertise was utilised by engaging Bike Taupō to form track access within DoC areas. Though no new access into the DoC Land will happen for this development, similarly a 1.5m pool fence will be provided on the proposed future development by committing to ensure these areas are protected and enjoyed by all.

Refer to Cheal Drawings 220225–SK301 and SK302 Conceptual Roading Layout.

7.1 Public Roads

7.1.1 Okaia Drive, Kahikatea Drive, and Road 1

The Okaia Drive and Kahikatea Drive intersection was completed as part of the Seven Oaks Subdivision Stage 2. These roads will match existing formations with a road reserve of 20m, an 8.5m wide carriageway crowned with a 3% crossfall to upright kerb and channel both sides, and berms of 5.7m and 5.8m wide. A bike friendly dedicated 1.8m wide cycleway will be constructed on one berm, with a dedicated 1.4m pedestrian footpath on the other.

Similar to the roads above, New Road 1 is proposed as a local street, with a road reserve of 20m, an 8.5m wide carriageway crowned with a 3% crossfall to upright kerb and channel both sides, and berms of 5.7m and 5.8m wide. A bike friendly dedicated 1.8m wide cycleway will be constructed on one berm, with a dedicated 1.4m pedestrian footpath on the other. The dual footpath and cycleways will extend to the northern boundary with the Terraces where it is anticipated there will only be a single footpath after that through the low density lots.

All public roads alignment meets the requirements of the District Plan Structure Plan, while enabling access and future proof development opportunities to the land above the site.

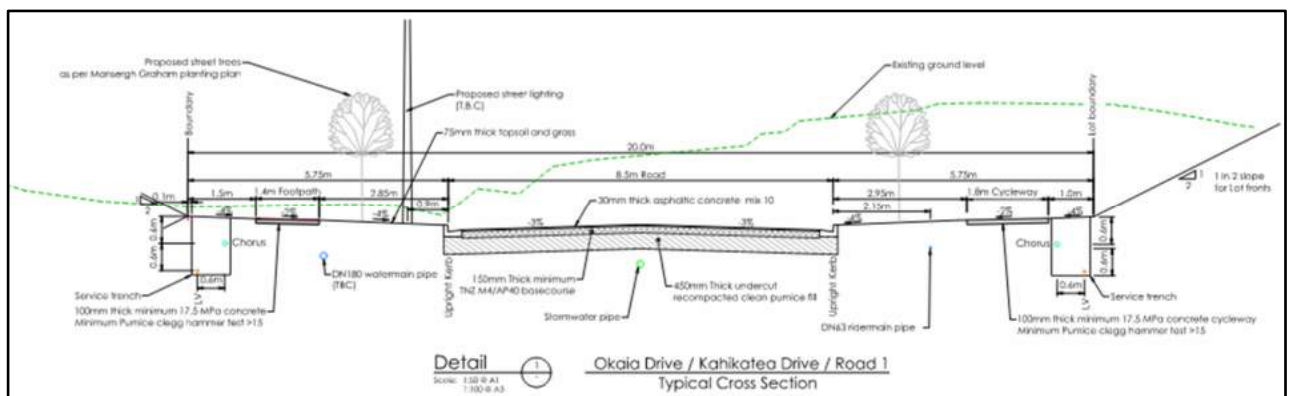

Figure 14 - Okaia Drive, Kahikatea Drive and Road 1 Typical Cross Section

7.1.2 Okaia Drive to the West (Cul-de-sac End)

After the intersection with Otaketake Drive, Stages 7 & 8 loop road, the Okaia Drive formation transitions to a road reserve width of 18m, with 7.0m wide carriageway crowned with a 3% crossfall to upright kerb and channel both sides and symmetrical berms of 5.5m. A bike friendly dedicated 1.8m wide cycleway will be constructed on one berm, with a dedicated 1.4m pedestrian footpath on the other. This transition follows the Code of Practice for public roads type providing access to less than 30 lots and less than 250 evpd.

7.1.3 Kahikatea Drive Extension

The extension of Kahikatea Drive into the Seven Oaks residentially zoned land was consented to occur with the construction of Stage 8. However, this portion of Kahikatea Drive (including all associated civil works) is currently being constructed as part of the Terraces subdivision at the time of writing this report.

7.1.4 Cul-de-Sacs (Road 2 and Road 3)

The remaining roads branch off the main roads to fill pockets of land within the subdivision. These cul-de-sacs service a small number of lots.

These cul-de-sacs are proposed as public road to vest and follow the Code with a road reserve of 16m, and 7.0m wide carriageway crowned with a 3% crossfall to upright kerb and channel on one side and a mountable kerb in the other. A 2.0m wide combined cycleway and pedestrian footpath will be constructed on one of the 4.5m wide berms, with a vegetated Stormwater swale on the

opposite 4.5m wide berm. Figure 15 below shows proposed section, similar to Silverleaf Way approved with Stage 2 of Seven Oaks.

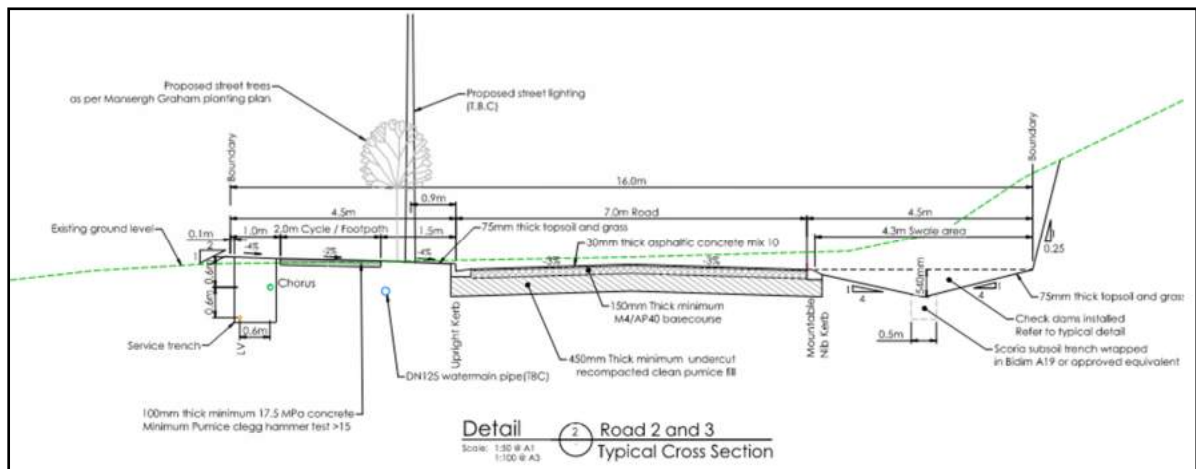

Figure 15 - Preliminary Cul-de-Sac Typical Cross Section

7.1.5 Private Roads

Private roads will be formed to match the widths vs number of lots serviced or longer. Pavement will compromise of a single crossfall with a proud nib on the uphill side and mountable kerb and channel on the downhill side to collect runoff from the pavement. In accordance with the Stormwater design code, primary protection from a 10% AEP design storm will be attenuated on-site through deep concrete lines soakholes.

7.1.6 Footpath and Cycleways

Corresponding to the network of cycleways and footpaths created within the Seven Oaks subdivision, a network will extend throughout the proposed Balance Land development, providing for safe and efficient connectivity without impacting on vehicular traffic. The overall layout of the proposed footpath and cycleway network throughout the development and within the Stormwater Reserves is shown on Conceptual Roading Layout Plans 220225-SK301 and SK302 attached in Appendix 2.

7.1.7 Roading Lighting

Roading lighting through all public roads will be continued in accordance with the style implemented in previous stages of Seven Oaks subdivision, to Council and best practice lighting design requirements.

8. WATER SUPPLY SERVICING

8.1 Water Supply Reticulation

Water modelling completed by WSP (Consultant for Taupō District Council) for the previous stages of Seven Oaks considered various options for the servicing of Stages 1 to 9, as well as the balance land area. The selected preferred option was to split the areas into a low-pressure zone (Stages 1 to 7) and a high-pressure zone (Stages 8 and 9 and the balance land). This option resulted in 100mm diameter water mains through the balance land.

However, at the time of WSP modelling completed for the balance land, 30 lots were assumed for the balance land. Given there are now proposed to be 100 lots, this modelling needs to be updated to determine pipe sizing for the proposed development as well as understand any effects on the existing infrastructure. At the time of writing this report, initial hydraulic modelling by WSP has been completed but is yet to be finalised. Preliminary indications are that the proposed lots can be serviced by existing Council infrastructure. Upon completion of the final WSP modelling report, pipe sizes and potential existing pipe upgrades can be confirmed.

Subject to confirmation from Council's modelling consultants, standard engineering practices suggest that a 225mm diameter high pressure main is required. This main is currently proposed along the length of Kahikatea Drive and up the proposed Road 1 which provides access to the property to the north of the balance land. Lower pressure 100mm mains and 50mm rider mains will be utilised for the servicing of the individual lots. Cul-de-sacs will require 100mm mains to extend to the ends of the cul-de-sacs to allow for fire hydrants. Should pipe sizes change or upgrades of existing piping networks be required, this will be addressed during detailed design following completion of the additional water modelling.

8.2 Kinloch Water Supply Capacity

With regards to the overall capacity of the Kinloch water supply, the analysis completed and described in the wastewater section of this report covers water supply as well. The only difference to be noted is where 40 lots for the Terraces to the north will not require sewer connection but will require water supply connections. Consequently, the 56 lots plus the 40 lots from the Terraces equates to 96 additional lots both planned for and proposed.

In summary, the proposed number of additional lots as well as potential in-fill lots in the community still fall within the number of lots already considered by TDC for water supply infrastructure.

Therefore, the infrastructure plan can accommodate the additional water supply requirements for the proposed balance land lots.

9. POWER AND TELECOM SERVICING

Preliminary communication with Chorus and Unison for power and telecommunications servicing has been completed. Both services providers have indicated that servicing for the proposed balance land lots can be accommodated with detailed design to be completed as required once the layout and civil designs have been confirmed.

10. DISCLAIMER

This Report has been prepared solely for the use of our client with respect to the particular brief given to Cheal Consultants Limited.

No liability is accepted in respect of its use for any other purpose or by any other person or entity. All future owners of this property should seek professional geotechnical advice to satisfy themselves as to its ongoing suitability for their intended use.

CHEAL CONSULTANTS LIMITED
10 November 2023

Appendix 1

Cheal Scheme Plan
220225-SC001

NOTES:

This plan has been prepared for the purpose of a resource consent application only. It is not a precise survey plan. As areas and dimensions are likely to vary upon survey it should not be attached to any sale & purchase agreements without an appropriate condition to cover such variations.



Aerial Imagery has been obtained from: Taupo District Council GIS and is provided under a Creative Commons Public License and with a DJI Matrice M300 and a Zenmuse P1 Camera. It has been provided as a guide to where the boundaries are positioned, or proposed on the ground, but may not be absolute.

Owner: Seven Oaks Kinloch Limited
Record of Title: 1109169

Asbuilt utilities may have other services in close proximity which are not shown for the purposes of this plan. Please identify existing utility locations and depths with Taupo District Council GIS before any field investigation or construction.

Underground services shown are indicative only. It is the contractors responsibility to identify existing utility locations and depths prior to construction.

KEY:

-  Reserve to Vest
-  District Plan Zone Boundary
-  Easement

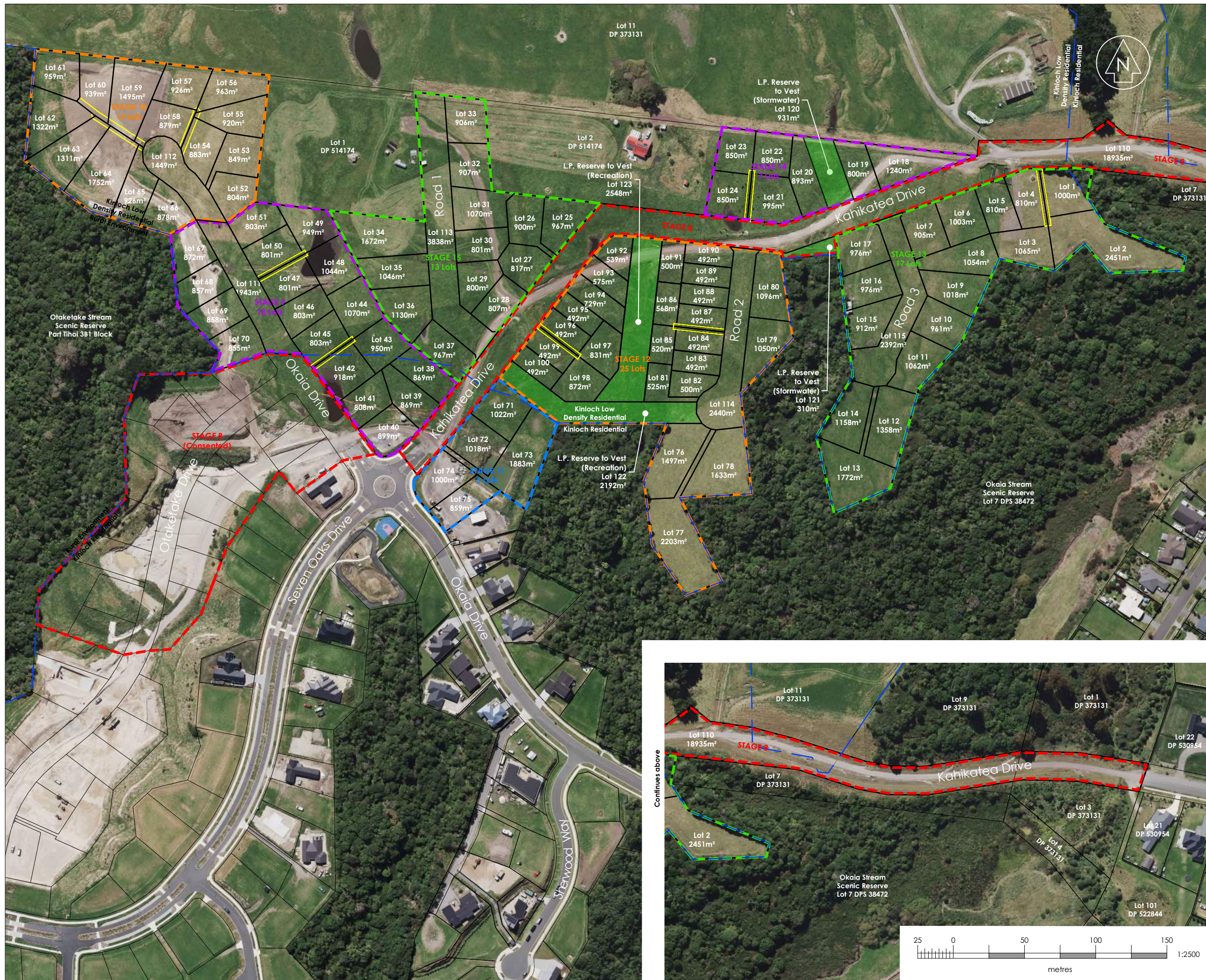

Continues below

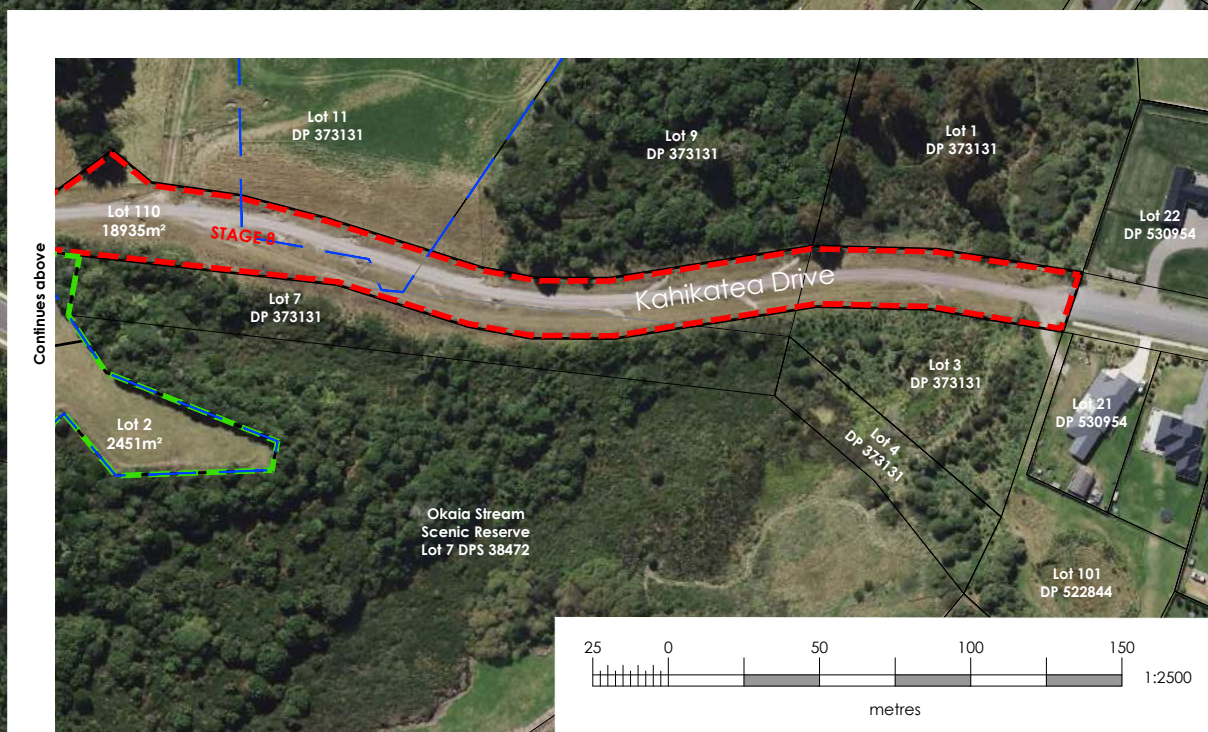

Continues above

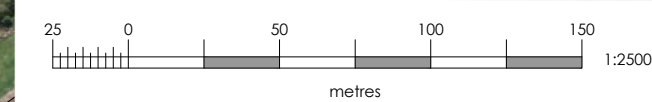

Rev	Date	Amendment	By	Chk	App
E	01/06/23	For Resource Consent	MR	LU	MR
D	09/12/22	Revised Lot Layout	KL	TWB	TWB
C	17/11/22	Revised Lot Layout	KL	TWB	TWB
B	25/08/22	Added Zone Boundaries	KL	OB	OB
A	10/08/22	First Issue	KL	OB	OB

Project Title
Seven Oaks Kinloch Ltd.
Okaiia Drive
Kinloch

Drawing Title
**Balance Land
Scheme Plan**

Surveyed			
Designed			
Drawn	K.Larsen	26/07/22	KL
Checked	O.Bucher	08/08/22	OB
Approved	O.Bucher	08/08/22	OB

Status **INFORMATION**

Scale A1 - | A3
A3 1:2500

Drawing Number 220225-SC001 | Rev E

Appendix 2

Cheal Concept Drawings for
Earthworks, Rooding and
Services



www.cheal.co.nz

NOTES:

This plan has been prepared for the purpose of a resource consent application only. It is not a precise survey plan. As areas and dimensions are likely to vary upon survey it should not be attached to any sale & purchase agreements without an appropriate condition to cover such variations.

Owner: Seven Oaks Kinloch Ltd

Record of Title: 1109169
Total Area: 18,255 ha

Reticulated services will require additional easements after final construction and development of the legal survey.

Rights of way to rear Lots are a minimum 4m wide.

Pool Fence along DOC Land Boundary.

Legend:

- Reserve to Vest (Recreation & Stormwater)
- Stormwater Overland Flow Path
- Design Contours Major
- Design Contours Minor
- Easement
- Existing Culvert
- Footpath 1.4m
- Cycleway 1.8m
- Combined Footpath & Cycleway 2.0m
- 3m Setback
- 5m Setback
- 7.5m Setback
- Stage 8 Boundary
- Stage 9 Boundary
- Stage 10 Boundary
- Stage 11 Boundary
- Stage 12 Boundary
- Stage 13 Boundary
- Stage 14 Boundary
- Stage 15 Boundary



B	16/05/23	For Resource Consent	JZL	SP	TWB
A	21/12/22	For Resource Consent	PH	LU	TWB
Rev	Date	Amendment	By Chk App		

Project Title
Seven Oaks Kinloch Limited
Okaiia Drive
Kinloch

Drawing Title
Balance Land
Earthworks
Existing Contour Plan

Surveyed	G.Ripoll	10/22	GR
Designed	S.Pen	12/22	SP
Drawn	P.Harris	21/12/22	PH
Checked	L.Ukrite	21/12/22	LU
Approved	T.Brand	21/12/22	TWB

Status **RESOURCE CONSENT**

Scale A1 1:1000 | A1
A3 1:2000

Drawing Number 220225-SK201 | Rev B

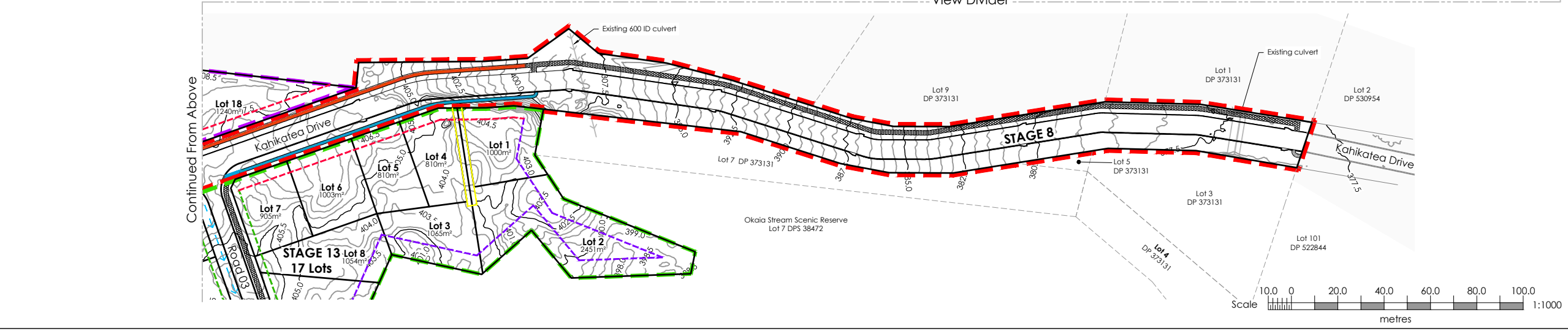
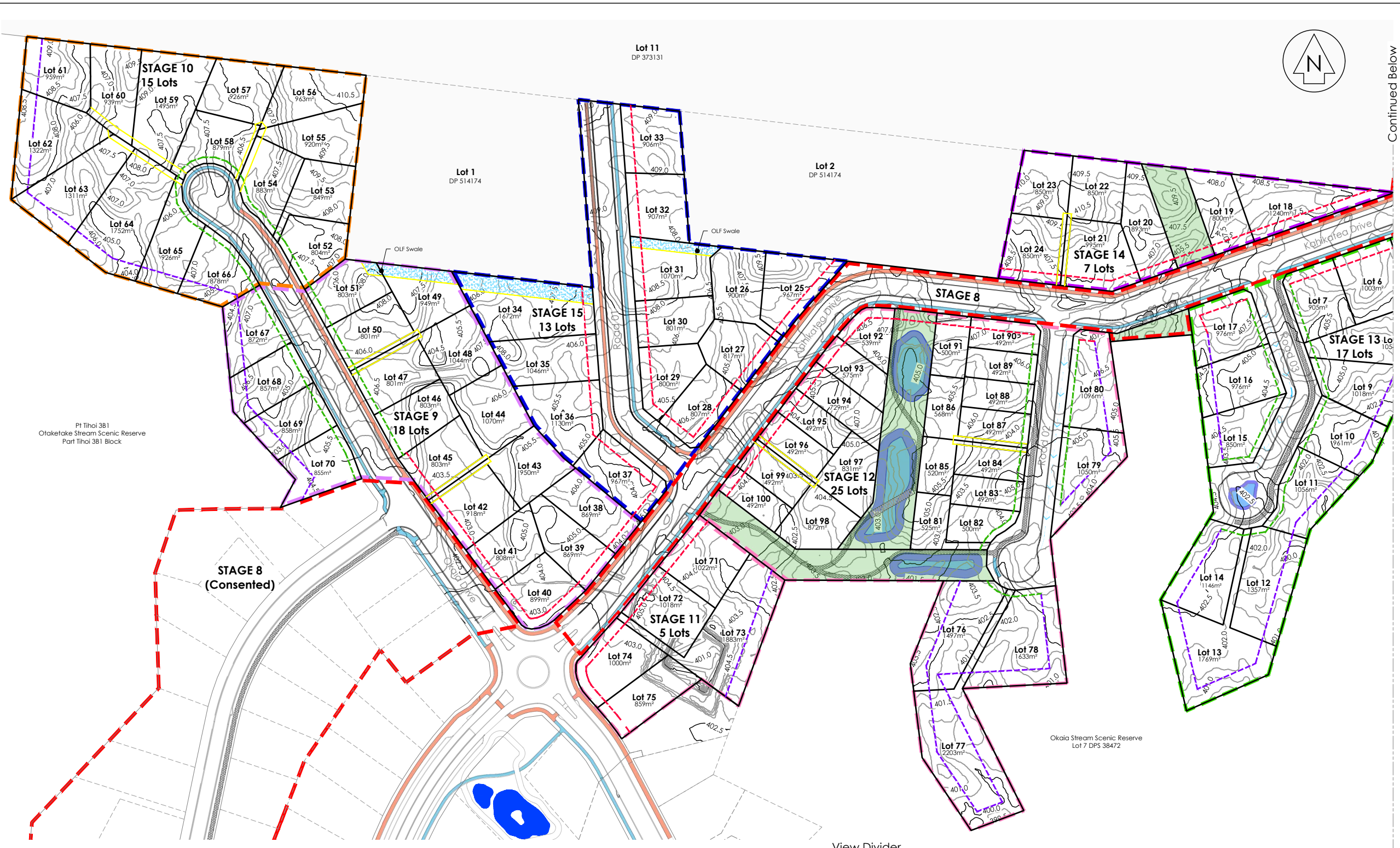



www.cheal.co.nz

NOTES:

This plan has been prepared for the purpose of a resource consent application only. It is not a precise survey plan. As areas and dimensions are likely to vary upon survey it should not be attached to any sale & purchase agreements without an appropriate condition to cover such variations.

Asbuilt utilities may have other services in close proximity which are not shown for the purposes of this plan. Please identify existing utility locations and depths with Taupo District Council GIS before any field investigation or construction.

Underground services shown are indicative only. It is the contractor's responsibility to identify existing utility locations and depths prior to construction.

Owner: Seven Oaks Kinloch Limited
Record of Title: 1109169

Legend:

- 3m Setback
- 5m Setback
- 7.5m Setback

Earthworks Volume Summary

Cut (m ³)	82,271m ³
Fill (m ³)	48,759m ³
Cut/Fill balance construction ± 0.0	
Excess Cut	1,074m ³



Continued Below



Elevations Table

Number	Minimum Elevation	Maximum Elevation	Color
1	-6	-4	Dark Red
2	-4	-3	Red
3	-3	-2	Red-Orange
4	-2	-1.5	Orange
5	-1.5	-1	Orange-Yellow
6	-1	-0.5	Yellow
7	-0.5	0	Light Green
8	0	0.5	Green
9	0.5	1	Light Green
10	1	1.5	Green
11	1.5	2	Light Green
12	2	3	Green
13	3	4	Dark Green
14	4	6	Blue



Rev	Date	Amendment	By	Chk	App
B	16/05/23	For Resource Consent	JZL	LU	TWB
A	21/12/22	For Resource Consent	PH	LU	TWB

Project Title
Seven Oaks Kinloch Limited
 Okaia Drive
 Kinloch

Drawing Title
Balance Land
 Earthworks
 Cut & Fill Plan

Surveyed	G.Ripoll	5/22	GR
Designed	S.Pen	11/22	SP
Drawn	P.Harris	21/12/22	PH
Checked	L.Urarte	21/12/22	LU
Approved	T.Brand	21/12/22	TWB

Status **RESOURCE CONSENT**

Scale	A1	1:1000	A1
	A3	1:2000	

Drawing Number **220225-SK203** | Rev **B**

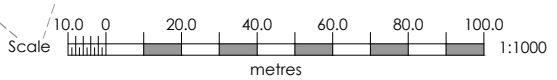
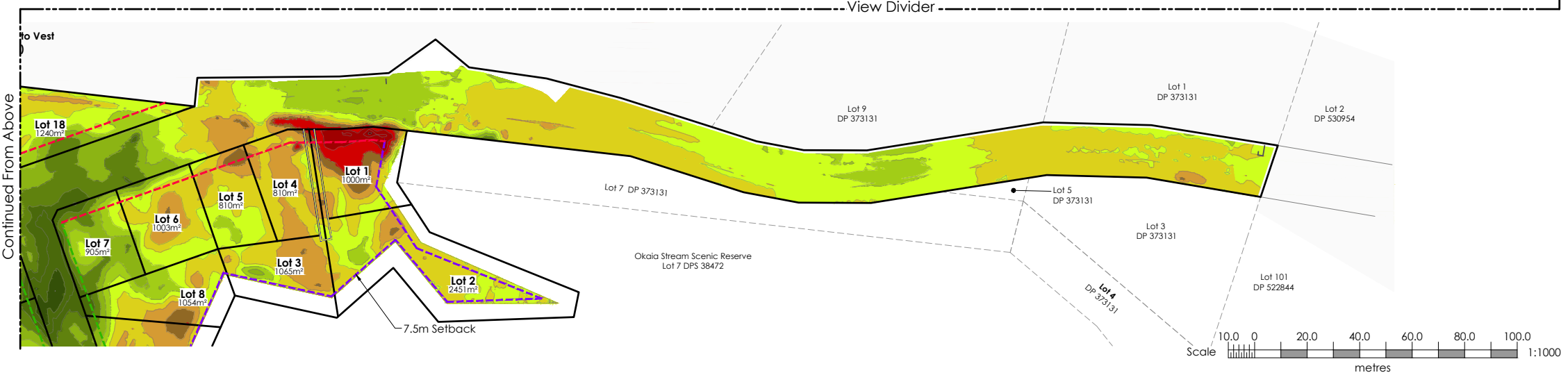



NOTES:

This plan has been prepared for the purpose of a resource consent application only. It is not a precise survey plan. As areas and dimensions are likely to vary upon survey it should not be attached to any sale & purchase agreements without an appropriate condition to cover such variations.

Owner: Seven Oaks Kinloch Ltd

Record of Title: 1109169



















Total Area: 18.255 ha

Reticulated services will require additional easements after final construction and development of the legal survey.

Rights of way to rear Lots are a minimum 4m wide.

Pool Fence along DOC Land Boundary.

Legend:

-  Reserve to Vest (Recreation & Stormwater)
-  Stormwater Overland Flow Path
-  Easement
-  ROW
-  Footpath 1.4m
-  Cycleway 1.8m
-  Combined Footpath & Cycleway 2.0m
-  Proposed Road
-  3m Setback
-  5m Setback
-  7.5m Setback
-  Stage 8 Boundary
-  Stage 9 Boundary
-  Stage 10 Boundary
-  Stage 11 Boundary
-  Stage 12 Boundary
-  Stage 13 Boundary
-  Stage 14 Boundary
-  Stage 15 Boundary



Rev	Date	Amendment	By	Chk	App
B	16/05/23	For Resource Consent	JZL	LU	TWB
A	21/12/22	For Resource Consent	PH	LU	TWB

Project Title
Seven Oaks Kinloch Limited
 Okaia Drive
 Kinloch

Drawing Title
Balance Land Roding
Conceptual Layout Plan
 Sheet 1 of 2

Surveyed	G.Ripoll	10/22	GR
Designed	S.Pen	12/22	SP
Drawn	P.Harris	21/12/22	PH
Checked	L.Ukarte	21/12/22	LU
Approved	T.Brand	21/12/22	TWB

Status **RESOURCE CONSENT**

Scale	A1	1:750	A1
	A3	1:1500	Rev

Drawing Number **220225-SK301** | B

Continued on SK302

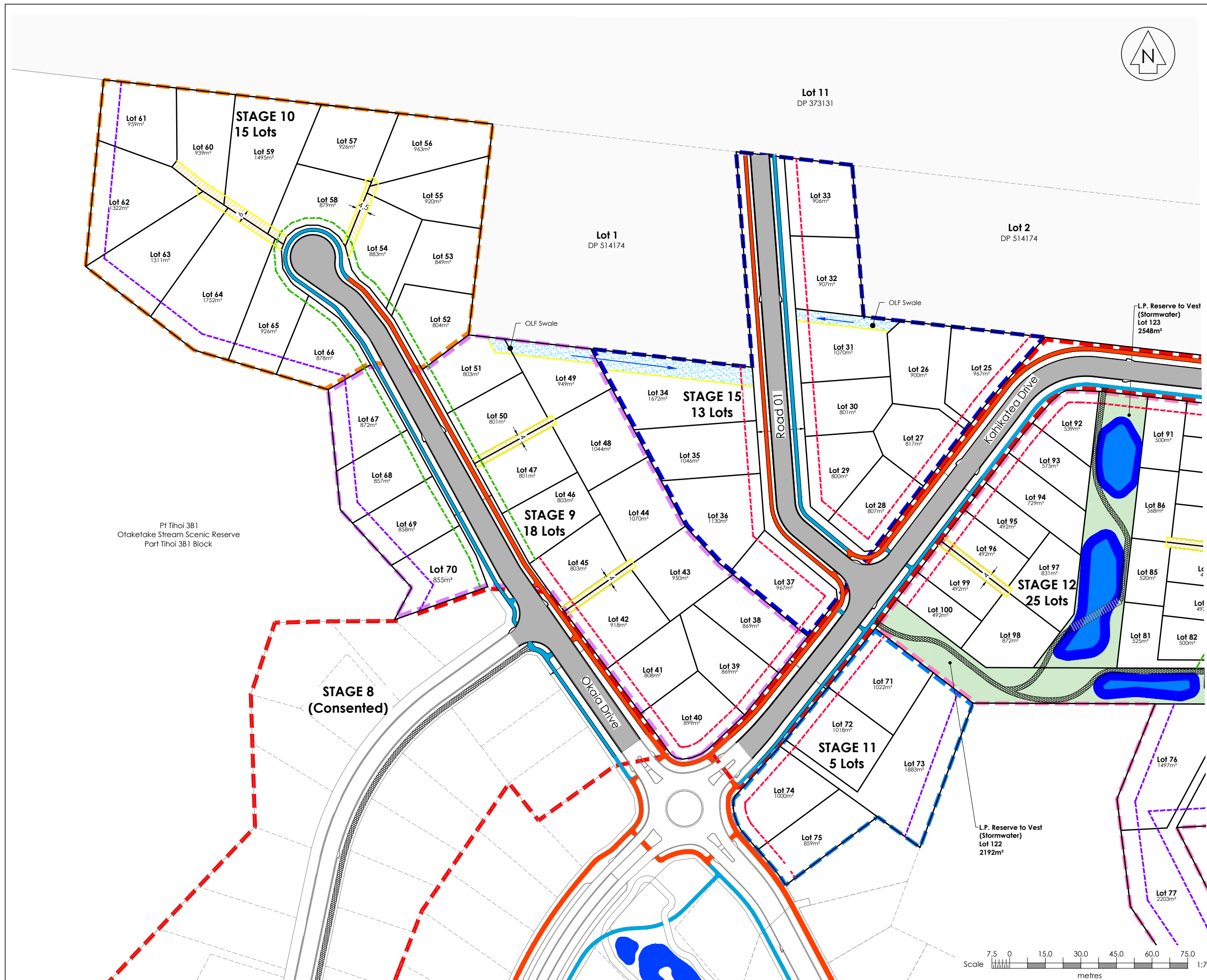

NOTES:

This plan has been prepared for the purpose of a resource consent application only. It is not a precise survey plan. As areas and dimensions are likely to vary upon survey it should not be attached to any sale & purchase agreements without an appropriate condition to cover such variations.

Owner: Seven Oaks Kinloch Ltd





















Record of Title: 1109169
Total Area: 18.255 ha

Reticulated services will require additional easements after final construction and development of the legal survey.

Rights of way to rear Lots are a minimum 4m wide.

Pool Fence along DOC Land Boundary.

Legend:

-  Reserve to Vest (Recreation & Stormwater)
-  Stormwater Overland Flow Path
-  Easement
-  ROW
-  Existing Culvert
-  Footpath 1.4m
-  Cycleway 1.8m
-  Combined Footpath & Cycleway 2.0m
-  Proposed Road
-  3m Setback
-  5m Setback
-  7.5m Setback
-  Stage 8 Boundary
-  Stage 9 Boundary
-  Stage 10 Boundary
-  Stage 11 Boundary
-  Stage 12 Boundary
-  Stage 13 Boundary
-  Stage 14 Boundary
-  Stage 15 Boundary



Rev	Date	Amendment	By	Chk	App
B	16/05/23	For Resource Consent	JZL	LU	TWB
A	21/12/22	For Resource Consent	PH	LU	TWB

Project Title
**Seven Oaks Kinloch Limited
Okaia Drive
Kinloch**

Drawing Title
**Balance Land Roding
Conceptual Layout Plan
Sheet 2 of 2**

Surveyed	G.Ripoll	10/22	GR
Designed	S.Pen	12/22	SP
Drawn	P.Harris	21/12/22	PH
Checked	L.Ularte	21/12/22	LU
Approved	T.Brand	21/12/22	TWB

Status **RESOURCE CONSENT**

Scale	A1	1:750	A1
	A3	1:1500	

Drawing Number **220225-SK302** Rev **B**

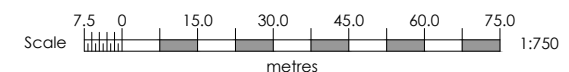
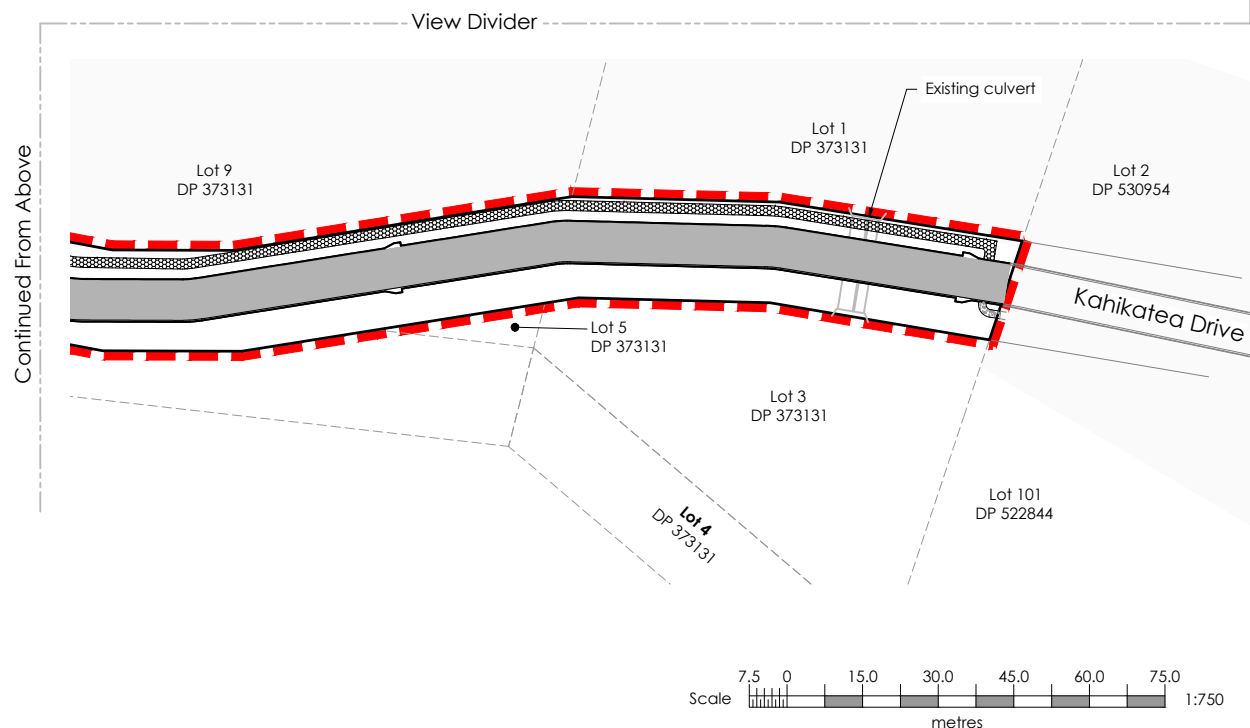
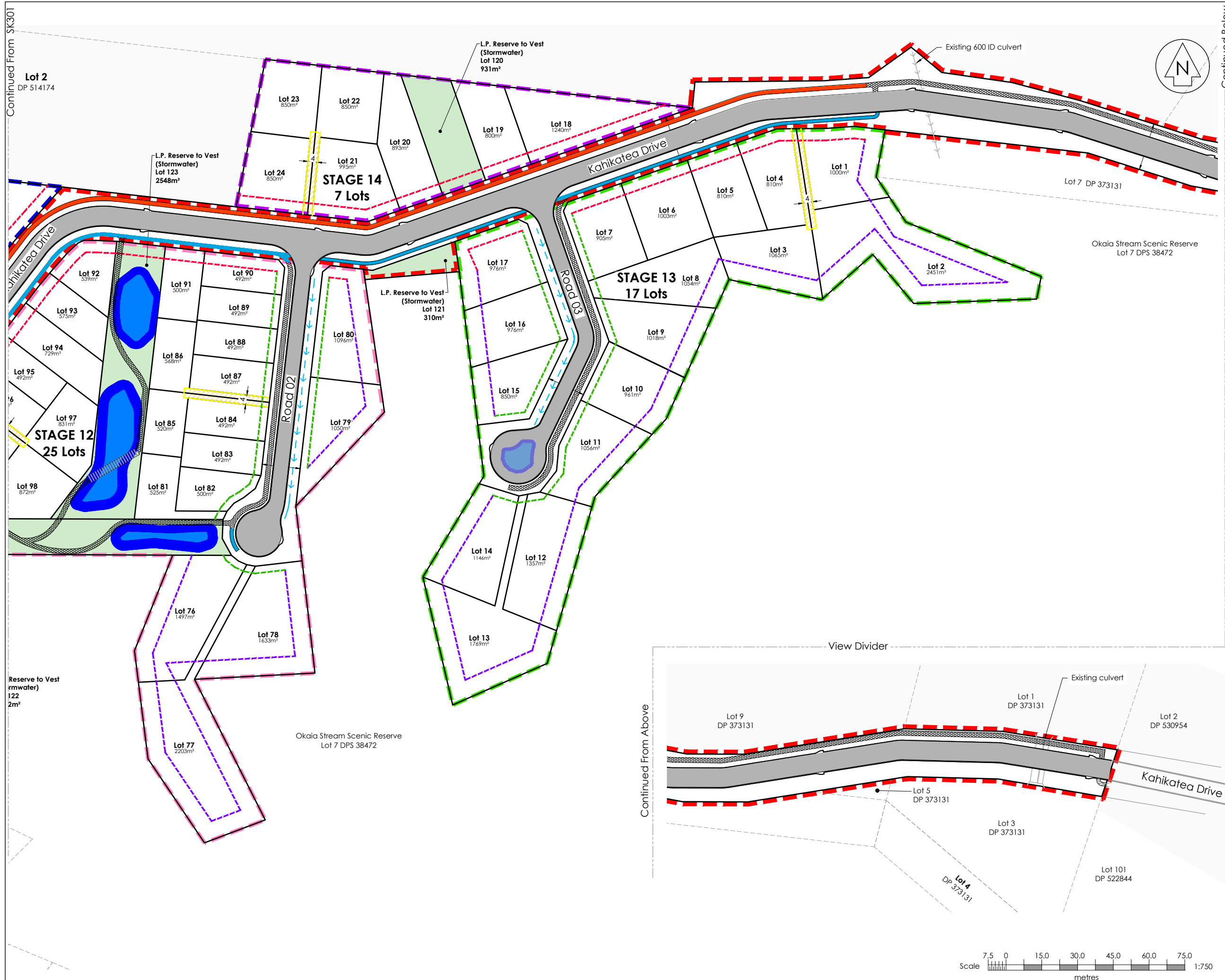

NOTES:

This plan has been prepared for the purpose of a resource consent application only. It is not a precise survey plan. As areas and dimensions are likely to vary upon survey it should not be attached to any sale & purchase agreements without an appropriate condition to cover such variations.

Owner: Seven Oaks Kinloch Ltd

Record of Title: 1109169
Total Area: 18.255 ha

Reticulated services will require additional easements after final construction and development of the legal survey.

Rights of way to rear Lots are a minimum 4m wide.

Pool Fence along DOC Land Boundary.

- Legend:**
- Stormwater Line Proposed
 - SWMH Proposed
 - Cesspit Proposed
 - SWSH Proposed
 - SW Soakage Pit
 - Sewer Line Proposed
 - Sewer Rising Main Proposed
 - SW Swale Proposed
 - SSMH Proposed
 - SSMH Existing
 - Reserve to Vest (Recreation & Stormwater)
 - Stormwater Overland Flow Path
 - Easement
 - ROW
 - Stage 8 Boundary
 - Stage 9 Boundary
 - Stage 10 Boundary
 - Stage 11 Boundary
 - Stage 12 Boundary
 - Stage 13 Boundary
 - Stage 14 Boundary
 - Stage 15 Boundary

SEVEN OAKS

Rev	Date	Amendment	By	Chk	App
B	16/05/23	For Resource Consent	JZL	LU	TWB
A	21/12/22	For Resource Consent	PH	LU	TWB

Project Title
**Seven Oaks Kinloch Limited
Okaia Drive
Kinloch**

Drawing Title
**Balance Land Services
Conceptual Layout Plan
Sheet 1 of 2**

Surveyed	G.Ripoll	10/22	GR
Designed	S.Pen	12/22	SP
Drawn	P.Harris	21/12/22	PH
Checked	L.Ukarte	21/12/22	LU
Approved	T.Brand	21/12/22	TWB

Status **RESOURCE CONSENT**

Scale	A1	1:750	A1
	A3	1:1500	

Drawing Number **220225-SK401** Rev **B**

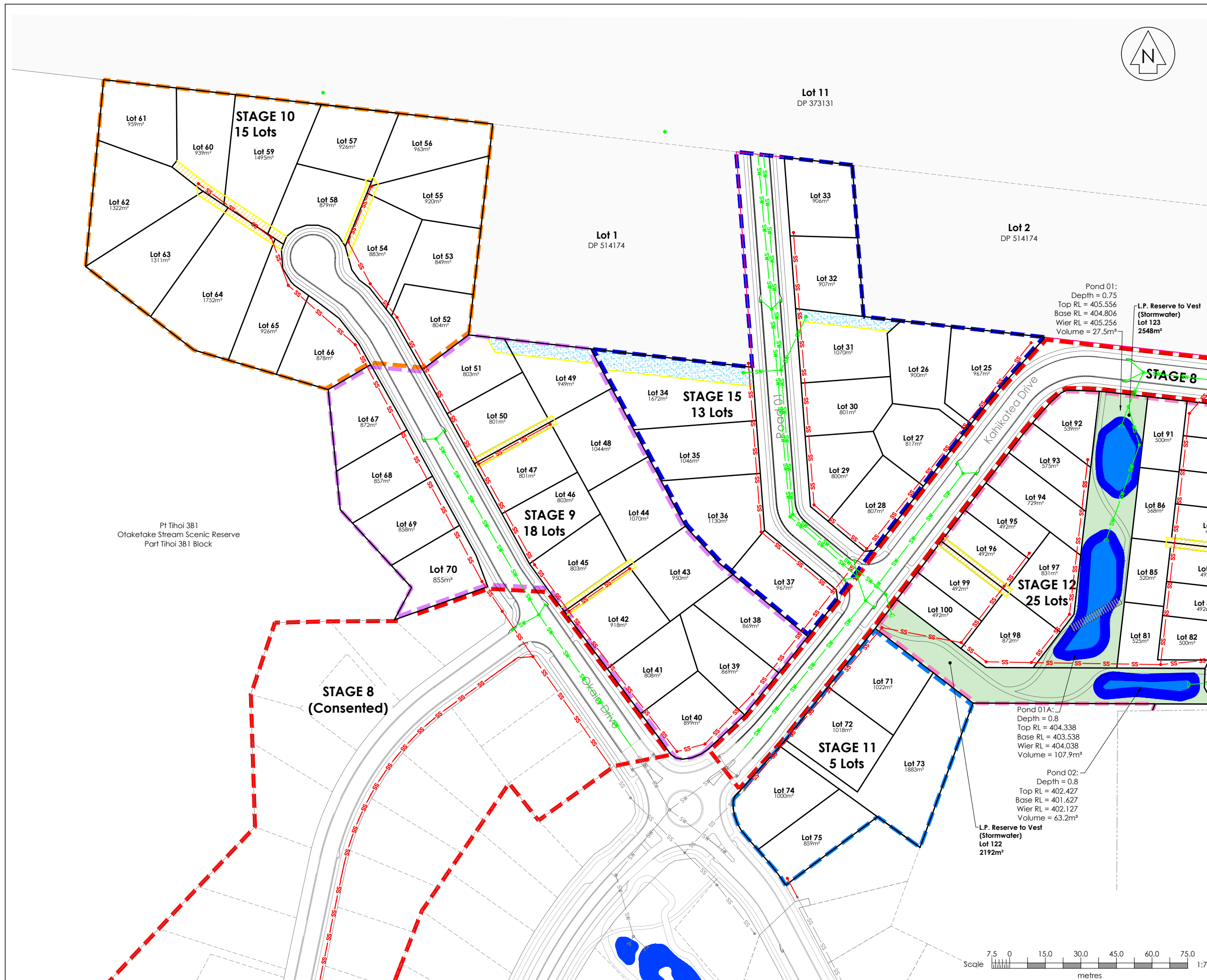

Continued on SK402

Continued From SK401

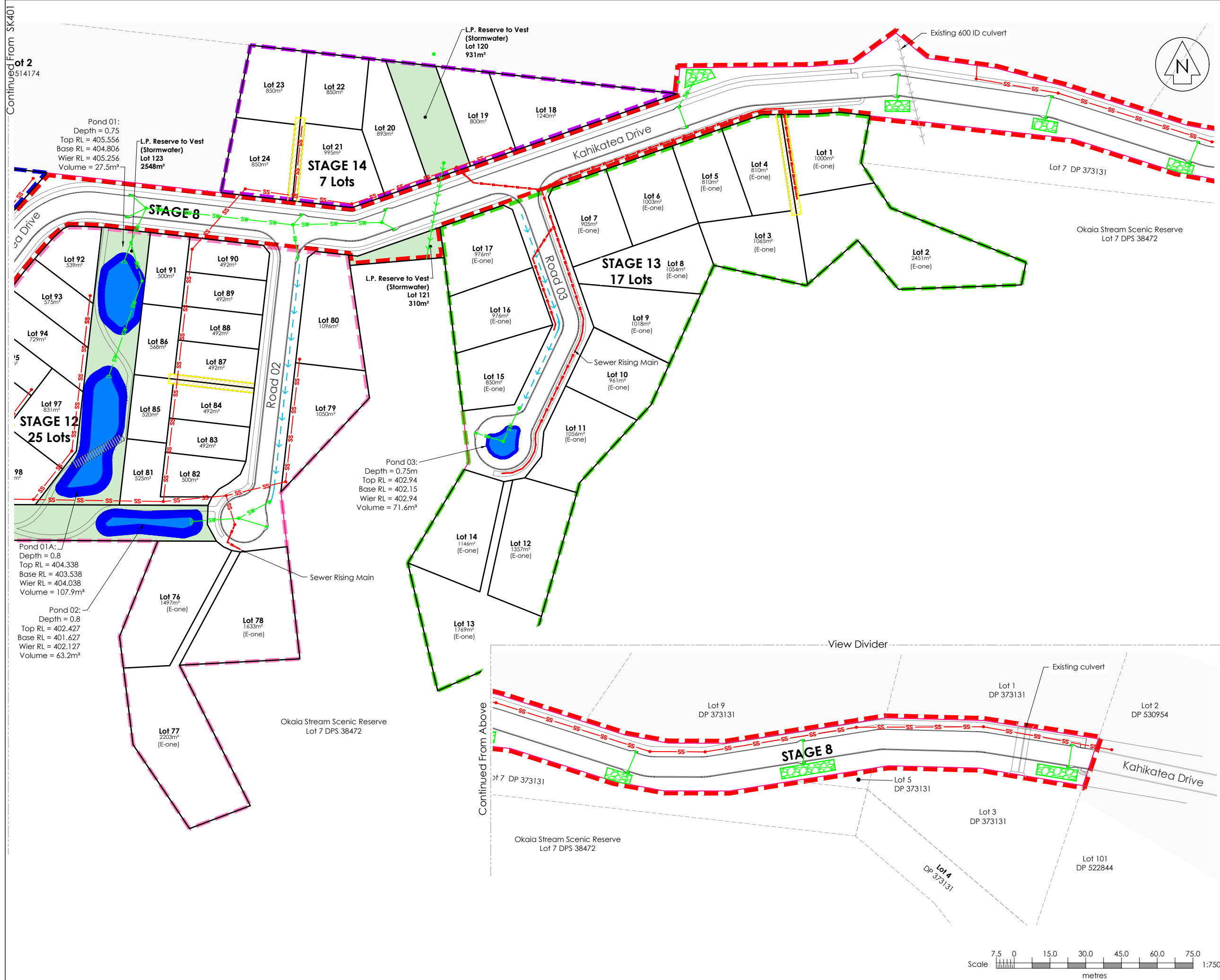

cheal

www.cheal.co.nz
NOTES:

This plan has been prepared for the purpose of a resource consent application only. It is not a precise survey plan. As areas and dimensions are likely to vary upon survey it should not be attached to any sale & purchase agreements without an appropriate condition to cover such variations.

Owner: Seven Oaks Kinloch Ltd

Record of Title: 1109169
Total Area: 18.255 ha

Reticulated services will require additional easements after final construction and development of the legal survey.

Rights of way to rear Lots are a minimum 4m wide.

Pool Fence along DOC Land Boundary.

- Legend:**
- Stormwater Line Proposed
 - SWMH Proposed
 - Cesspit Proposed
 - WSH Proposed
 - SW Soakage Pit
 - Culvert Proposed
 - Individual SS Pump Station (E-one)
 - Sewer Line Proposed
 - Sewer Rising Main Proposed
 - SW Swale Proposed
 - SSMH Proposed
 - SSMH Existing Reserve to Vest (Recreation & Stormwater)
 - Stormwater Overland Flow Path
 - Easement
 - ROW
 - Stage 8 Boundary
 - Stage 9 Boundary
 - Stage 10 Boundary
 - Stage 11 Boundary
 - Stage 12 Boundary
 - Stage 13 Boundary
 - Stage 14 Boundary
 - Stage 15 Boundary

SEVEN OAKS

B	16/05/23	For Resource Consent	JZL	LU	TWB
A	21/12/22	For Resource Consent	PH	LU	TWB
Rev	Date	Amendment	By Chk App		

Project Title
**Seven Oaks Kinloch Limited
Okaia Drive
Kinloch**

Drawing Title
**Balance Land Services
Conceptual Layout Plan
Sheet 2 of 2**

Surveyed	G.Ripoll	10/22	GR
Designed	S.Pen	12/22	SP
Drawn	P.Harris	21/12/22	PH
Checked	L.Ukarte	21/12/22	LU
Approved	T.Brand	21/12/22	TWB

Status **RESOURCE CONSENT**

Scale	A1	1:750	A1
	A3	1:1500	Rev

Drawing Number
220225-SK402 | B

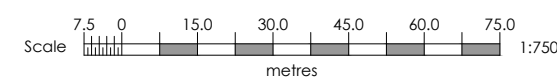

Appendix 3

Lisland Pump Station Storage
Upgrade Calculations,
Proposed Sketch Layout and
Background

Design Brief

- Lisland existing Wastewater Treatment Plant assessment to incorporate Balance Land lots at Kinloch for allowance for new 80 Lots.
- Gravity connection

Stage-8: 4 lots with gravity connection not previously allowed for
 Stage-2: 2 lots

Balance Land: 100 New lots. 20 lots will be serviced via individual pump stations.

Totalling=100+6-20-7 permitted for balance land =**79** Lots for storage capacity required.

- TDC requirements for storage capacity based on 12 hour emergency storage
- HEU and rates as per NZS 4404/2010 and TDC CoP
- Refer to Scheme Plans 220225 - SC001
- Existing Lisland Drive Pump Station as per Layout Plan by Connell Wagner 7579-15

Information used :

$$HEU := 2.7 \quad \text{rate} := 250 \frac{\text{L}}{\text{day}} \quad [\text{Houses}]$$

$$PF := 2.3 \quad PW := 3.5 \quad \text{Peak factors}$$

1.- Volume Generation

86 Lots Scenario

$$H := 86 \quad \text{Number of lots requested by Client}$$

$$ADWF_t := \overrightarrow{H \cdot HEU \cdot \text{rate}} = 0.672 \frac{\text{L}}{\text{s}} \quad \text{Average Dry Weather Flow}$$

$$WW_vol_t := ADWF_t \cdot 24 \text{ hr} = 58.05 \text{ m}^3 \quad \text{Wastewater generation on 24hr}$$

79 Lots Scenario

$$H_{79} := 79 \quad \text{Scheme Plan Design Number of Lots 85}$$

$$ADWF_{79} := \overrightarrow{H_{79} \cdot HEU \cdot \text{rate}} = 0.62 \frac{\text{L}}{\text{s}} \quad \text{Average Dry Weather Flow}$$

$$WW_vol_{79} := ADWF_{79} \cdot 24 \text{ hr} = 53.33 \text{ m}^3 \quad \text{Wastewater generation on 24hr}$$

2.- Additional Flows

As requested by client 86 Lots

Scheme Plan 79 Lots

$$WW_vol_t = 58050 \text{ L}$$

$$WW_vol_{79} = 53325 \text{ L}$$

$$ADWF_t = 0.672 \frac{\text{L}}{\text{s}}$$

$$ADWF_{79} = 0.62 \frac{\text{L}}{\text{s}}$$

$$PDWF_t := ADWF_t \cdot PF \cdot PW = 5.41 \frac{\text{L}}{\text{s}}$$

$$PDWF_{79} := ADWF_{79} \cdot PF \cdot PW = 4.97 \frac{\text{L}}{\text{s}}$$



Client: Seven Oaks Kinloch Ltd
 Address: Okaia Drive, Kinloch
 Job Description: WWTP calculations

Date: 15/05/2023
 Designer/Reviewed: LU/TWB
 Job Number: 220225

3. - Storage Requirement (12 hours)

$$Em.St := (50)\% \cdot WW_vol_t = 29.03 \text{ m}^3$$

86Lots - Emergency storage

$$Em.St_{79} := (50)\% \cdot WW_vol_{79} = 26.66 \text{ m}^3$$

79Lots - Emergency storage

$$Tank := 8 \cdot 2.440 \text{ m} \cdot (1.35 \text{ m})^2 \cdot \frac{\pi}{4} = 27.94 \text{ m}^3$$

Tank dimensions 9 lengths x 2.440m L
x 1.35m Diam

*Note: Balance Land contain 7 Lots as permitted sewer connection as per District Plan. Therefore 86 No and 79No Lots scenarios have been used. Proposed storage tank volumes are above both scenatios.

4. - Assessment Comments

- Two scenarios were assessed 86 Lots and 79 Lots.
- Existing pumps size and capacity TBC to check the performance of the PSI pumps and satisfied that it has enough to handle the incoming additional flows above existing flows at peak. Hours run or well drawdown tests will give a good indication of the actual pump performance.
- The above assessment needs to be discussed with TDC and approved. Data from existing pumps needs to be confirmed.



Client: Seven Oaks Kinloch Ltd
Address: Okaia Drive, Kinloch
Job Description: WWTP calculations

Date: 15/05/2023
Designer/Reviewed: LU/TWB
Job Number: 220225

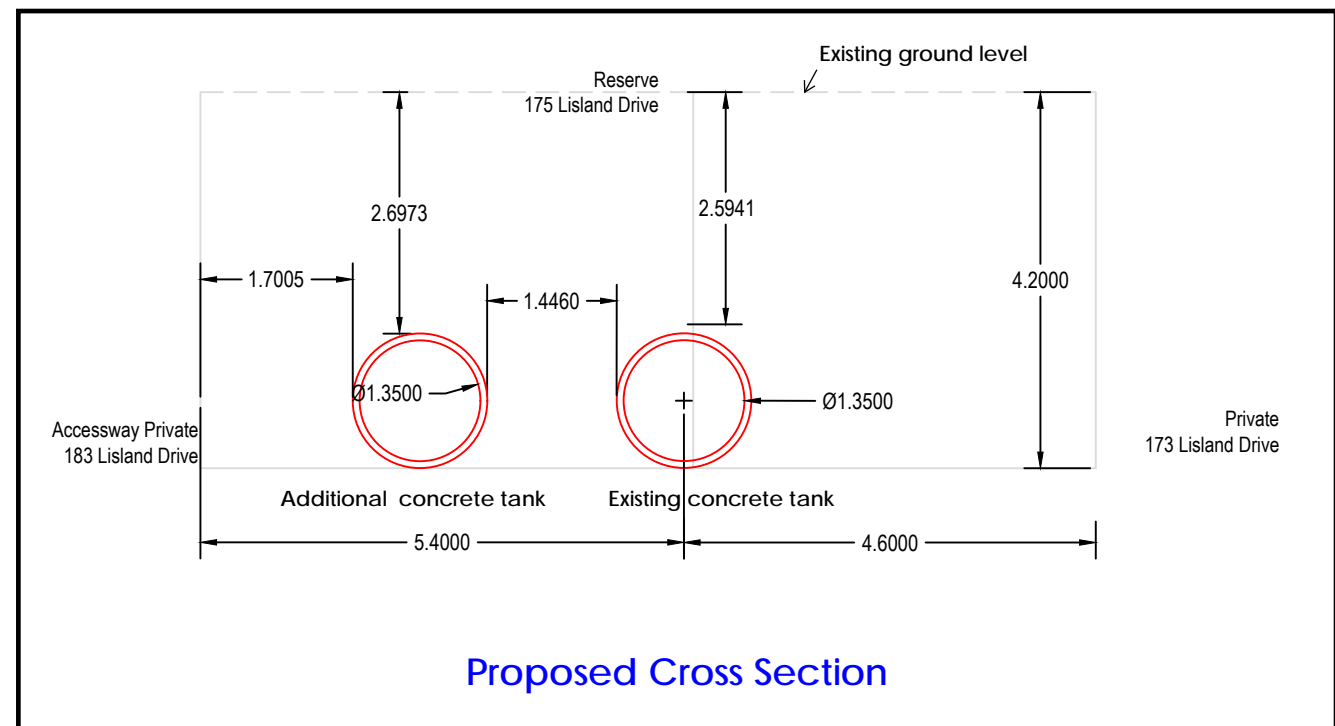
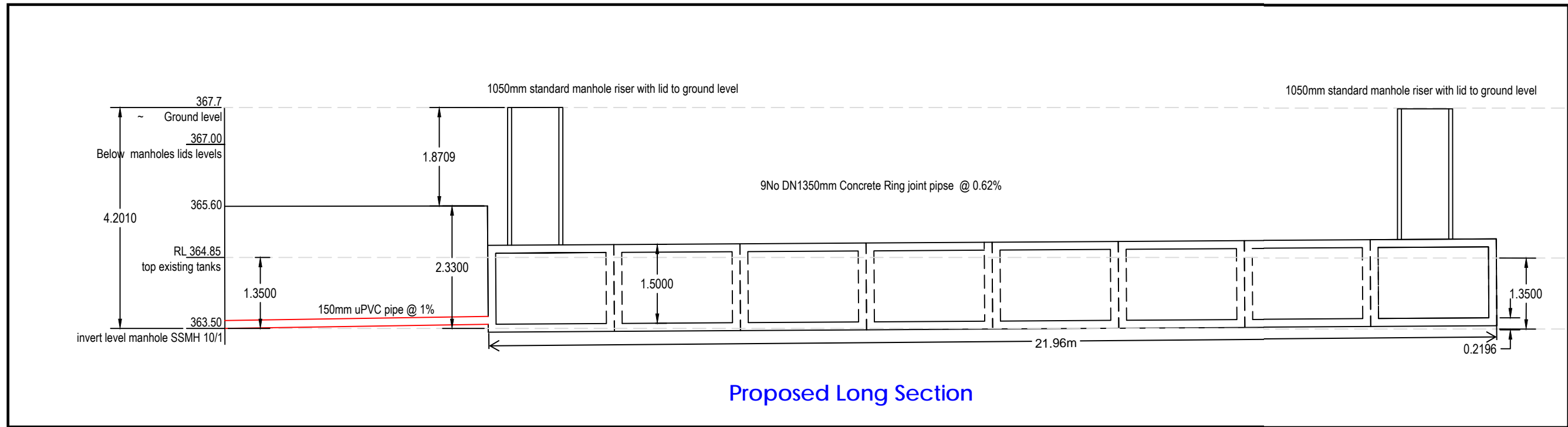

	Client: Seven Oaks Kinloch Limited	Date: 29/05/23
	Address: Okaia Drive, Kinloch	Designer: LU/TWB
	Design: Lisland Drive Storage Tank Upgrade	Job Number: 220225
	Title: Proposed Storage Tank Sections	Plan: SK-001

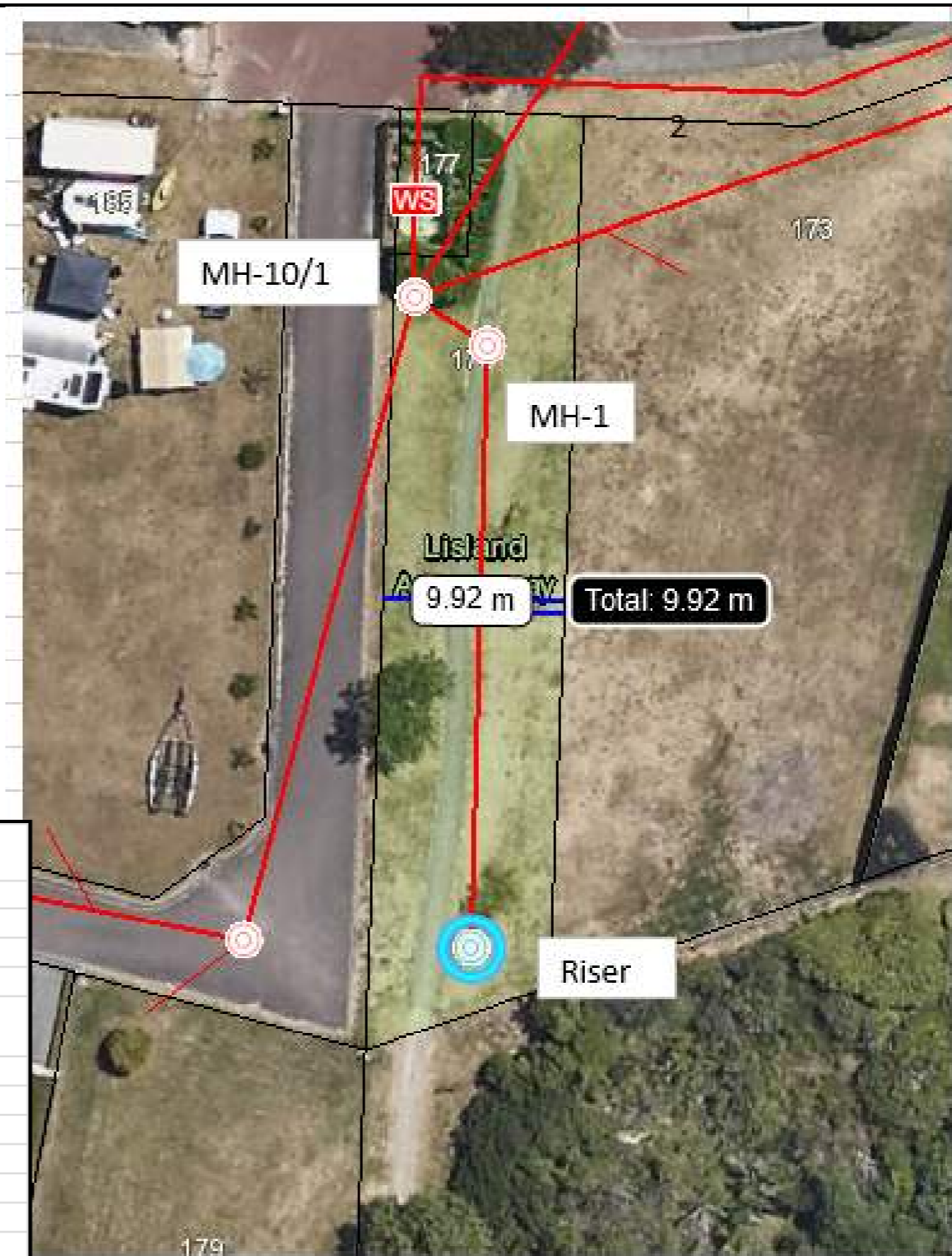

Details				
MH 10/1	MH 1	Riser	Tanks	MH4
Asset_ID	Asset_ID	Asset_ID	Asset_ID	Asset_ID
SCMH1328	SCMH1306	SCMH1305	SCMN0278	SCMH1327
ASSET_TYPE	ASSET_TYPE	ASSET_TYPE	ASSET_TYPE	ASSET_TYPE
Standard Manhole	Standard Manhole	Standard Manhole	Overflow pipe used as storage tank	Standard Manhole
Asset_Sub_Type	Asset_Sub_Type	Asset_Sub_Type	Material	Asset_Sub_Type
Concrete	Concrete	Concrete	RC	Concrete
DIAMETER	DIAMETER	DIAMETER	DIAMETER	DIAMETER
1050	1050	1050	1350	1050
WIDTH	WIDTH	WIDTH	HEIGHT	WIDTH
1050	1050	1050	1350	1050
Community	Community	Community	Community	Community
Kinloch	Kinloch	Kinloch	Kinloch	Kinloch
Depth_to_invert	Depth_to_invert	Depth_to_invert	Quantity_Length	Depth_to_invert
3.78	4.1	3.25	32.99	2.72
Invert_Level	Invert_Level	Invert_Level	Install_Date	Invert_Level
363.93	363.62	363.82	Oct 21, 2002 1:00 PM	364.28
Lid_Level	Lid_Level	Lid_Level	Condition	Lid_Level
367.71	367.72	367.07	N/A	367
Install_Date	Install_Date	Install_Date	Accuracy	Install_Date
Oct 21, 2002 1:00 PM	Oct 21, 2002 1:00 PM	Oct 21, 2002 1:00 PM	N/A	Oct 21, 2002 1:00 PM
Condition	Condition	Condition	Performance	Condition
Excellent	Excellent	Excellent	Excellent	Excellent
Accuracy	Accuracy	Accuracy	US_Invert	Accuracy
Excellent	Excellent	Excellent	363.82	Excellent
	Performance	Performance	DS_Invert	Performance
	Excellent	Excellent	0	Excellent

Data from MAPI (GIS TDC data)

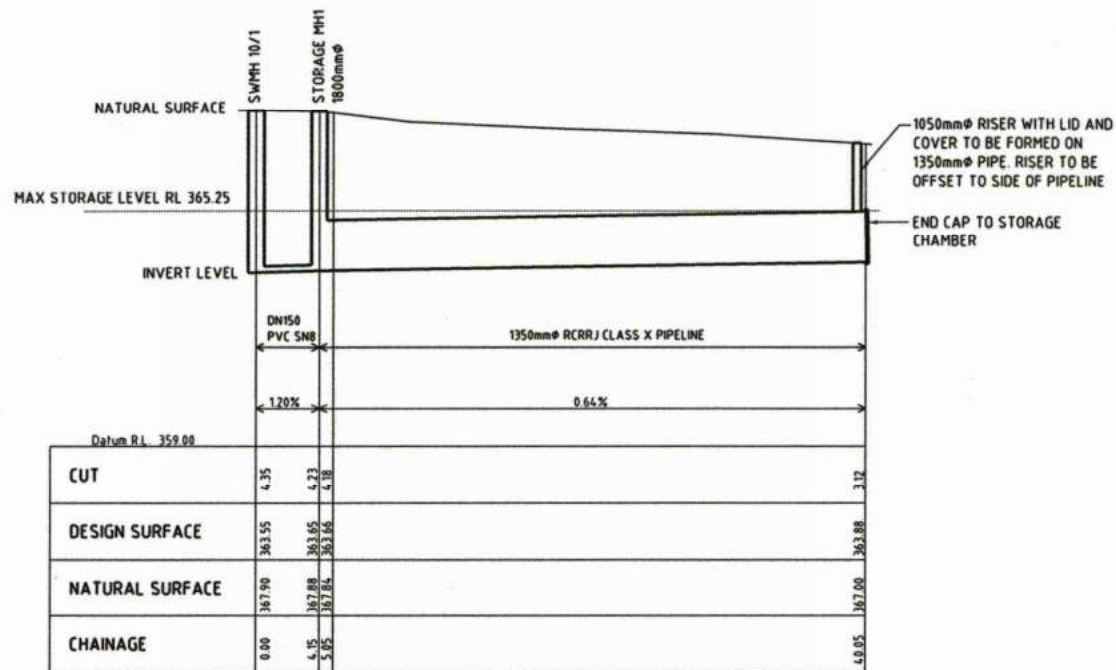

SANITARY SEWER LONGITUDINAL ELEVATION - STORAGE PIPELINE

Scale Horizontal 1:250 Vertical 1:100

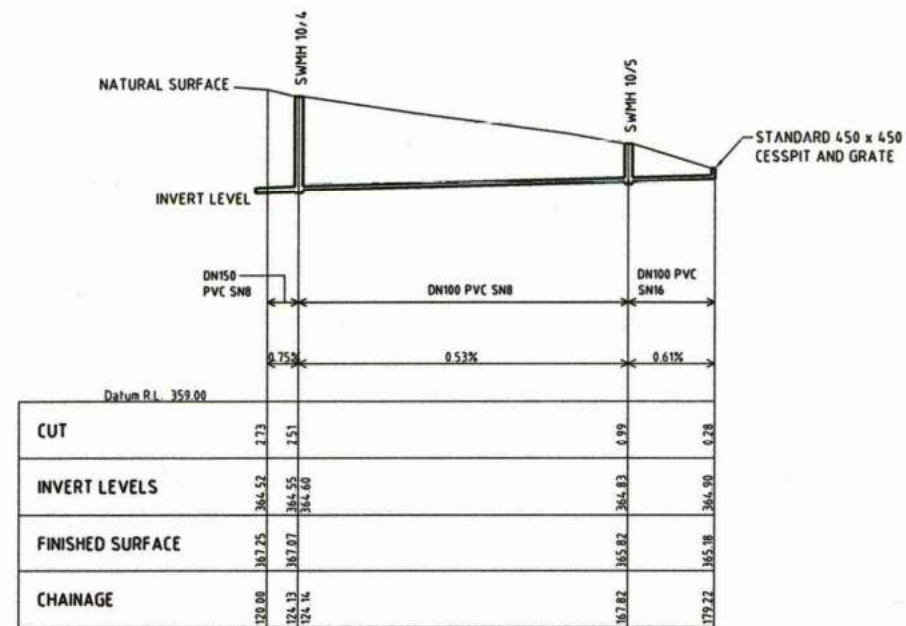

SANITARY SEWER LONGITUDINAL ELEVATION - OVERFLOW PIPELINE

Scale Horizontal 1:500 Vertical 1:100
(Refer to dwg. 7579-15-16 for location)

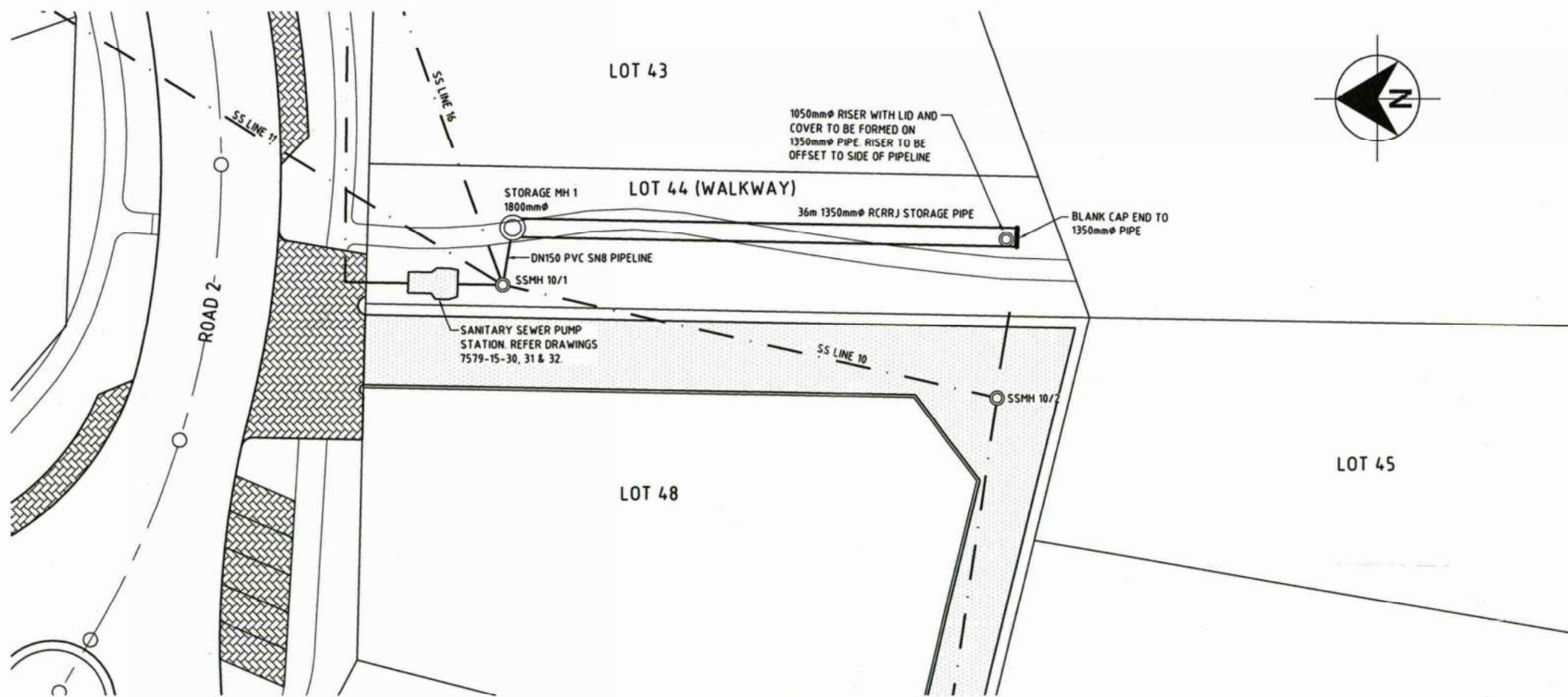

PLAN
1:200

CONSTRUCTION

Rev.	Date	Revision Details	By	Ver.	App.
A	06.09.02	CONSTRUCTION ISSUE	CF		
01	28.06.02	PRELIMINARY ISSUE	CF		

Connell Wagner

Connell Wagner Ltd
143 Durham Street (PO Box 2292)
Tauranga, New Zealand
Telephone: +64 7 578 6183
Facsimile: +64 7 578 6143
Email: TGAcco@connwag.com

A person using Connell Wagner drawings and other data accepts the risk of:
1. using the drawings and other data in electronic form without requesting and checking them for accuracy against the original hard copy version,
2. using the drawings or other data for any purpose not agreed to in writing by Connell Wagner.

Client:
LISLAND PROPERTIES LTD

Project:
**HOLY OAKS STAGE 2B
RESIDENTIAL SUBDIVISION
KINLOCH**

Drawn	Signed	Date
CF		
Designed	Signed	Date
GH		
Verified	Signed	Date
NR		
Approved	Signed	Date
AL		

Drawing Title:
**SANITARY SEWER STORAGE PIPE
LAYOUT PLAN AND
LONGITUDINAL SECTIONS**

CW Project No.	7579-15
Scale	AS SHOWN @ A1
Drawing No.	42
Rev.	A

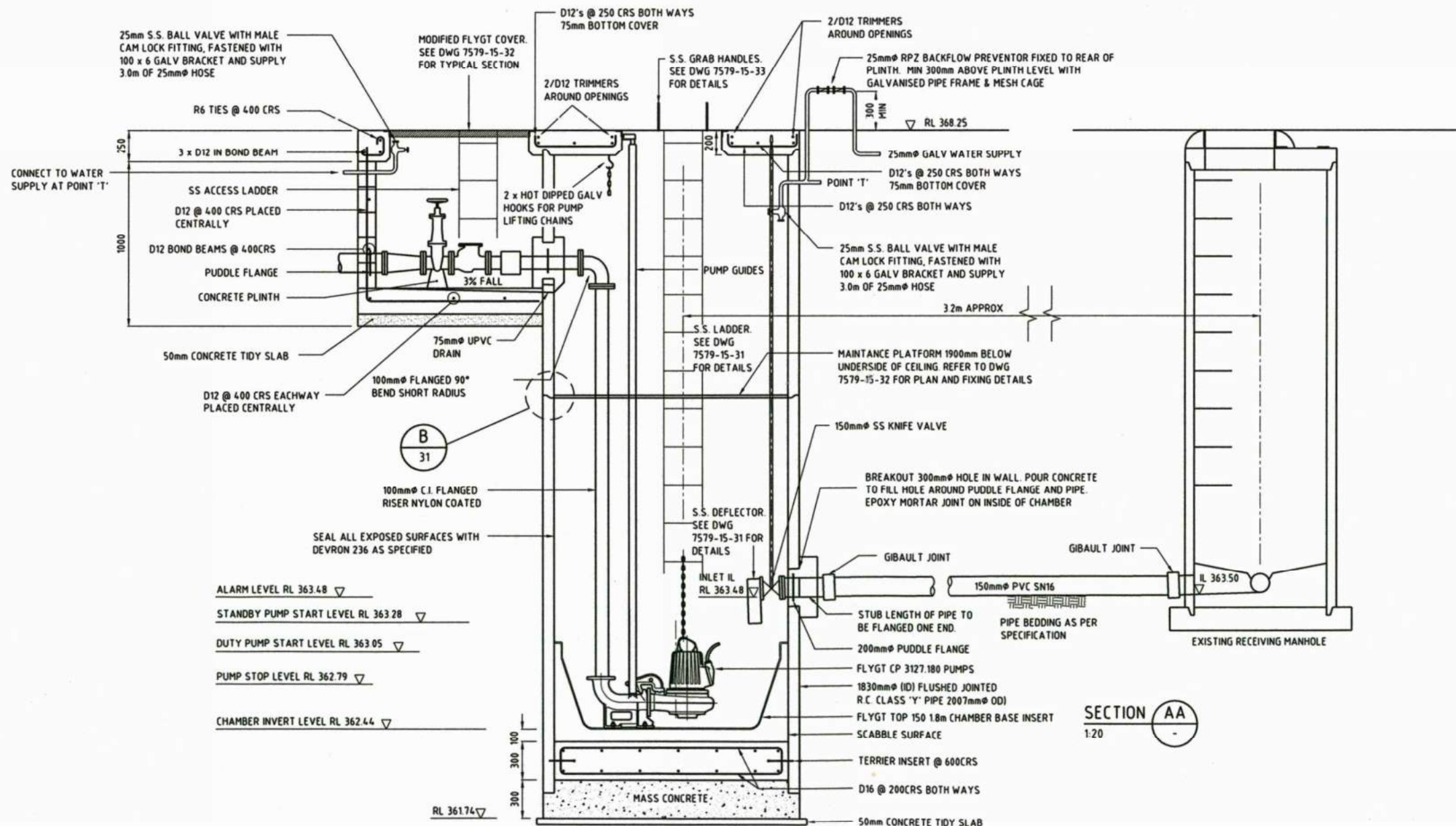
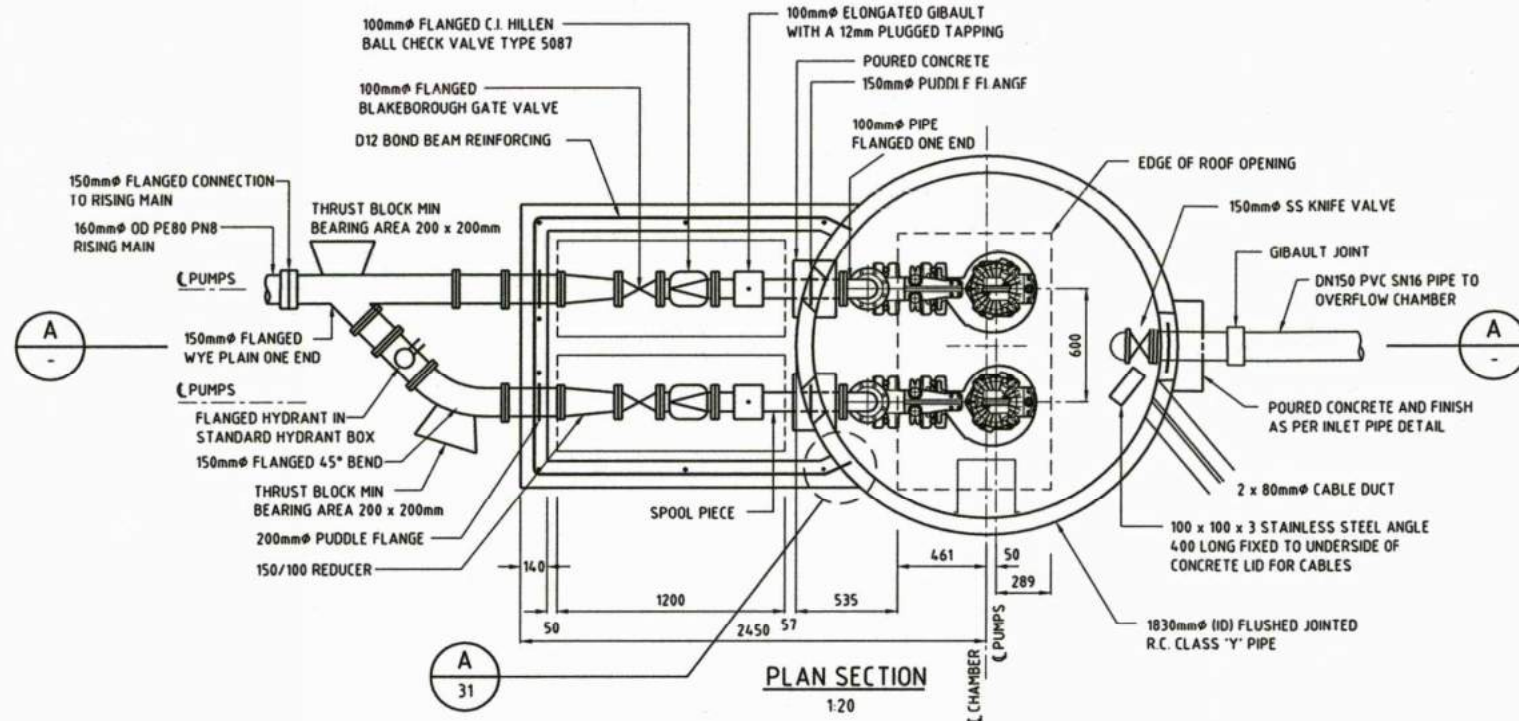

- ALARM LEVEL RL 363.48
- STANDBY PUMP START LEVEL RL 363.28
- DUTY PUMP START LEVEL RL 363.05
- PUMP STOP LEVEL RL 362.79
- CHAMBER INVERT LEVEL RL 362.44

NOTES:

1. ALL PIPEWORK TO BE CAST IRON UNLESS STATED OTHERWISE.
2. BACKFILL TO CHAMBER OMITTED FOR CLARITY.
3. ALL ELECTRICAL INSTALLATION, CONNECTIONS, TELEMETRY AND COMMISSIONING TO MEET REQUIREMENTS OF TAUPU DISTRICT COUNCIL.
4. INCLUDE FOR FULL INSTALLATION AND COMMISSIONING OF ABOVE GROUND STANDBY GENERATION SET, INCLUDING ROBUST WEATHERPROOF HOUSING TO MEET TDC REQUIREMENTS.

Rev	Date	Revision Details	By	Ver.	App.
B	06.09.02	PUMP TYPE REVISED	JJF	CF	
A	12.06.02	CONSTRUCTION ISSUE	JJF	CF	
03	19.04.02	TENDER ISSUE	JJF	CF	
02	8/4/02	AMENDMENTS MADE	JJF		
01	2/4/02	PRELIMINARY ISSUE	JJF		

Connell Wagner
 Connell Wagner Ltd
 143 Durham Street (PO Box 2292)
 Tauranga, New Zealand
 Telephone: +64 7 578 6183
 Facsimile: +64 7 578 6143
 Email: TCAcc@connwag.com

A person using Connell Wagner drawings and other data accepts the risk of:
 1. using the drawings and other data in electronic form without requesting and checking them for accuracy against the original hard copy versions.
 2. using the drawings or other data for any purpose not agreed to in writing by Connell Wagner.

Client:
LISLAND PROPERTIES LTD

Project:
**HOLY OAKS STAGE 2B
 RESIDENTIAL SUBDIVISION
 KINLOCH**

Drawing Title:
**SANITARY SEWER
 PUMP STATION,
 VALVE CHAMBER &
 WET WELL DETAILS**

Drawn	Signed	Date	Verified	Signed	Date
JJF			NR		
Designed	Signed	Date	Approved	Signed	Date
NR			AL		

CW Project No. **7579-15** Scale: **AS SHOWN @ A1**

Drawing No. **30** Revision: **B**

CONSTRUCTION

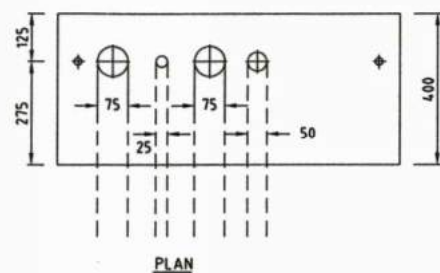
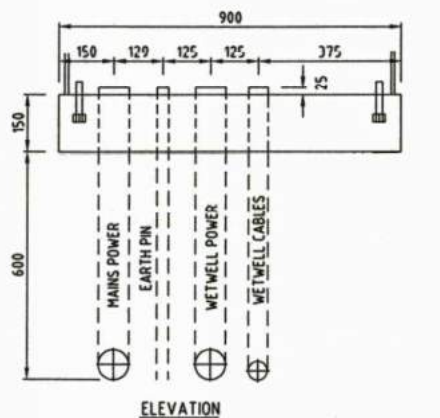

PLINTH DETAILS

NOTES:

- PLINTH TO BE CAST ON CONSOLIDATED BASE
- PIPE BENDS TO BE LONG RADIUS BENDS OR MADE FROM 2 x 45° BENDS
- PLINTH SURFACE TO BE TROWELLED FINISH
- PLINTH TO BE REINFORCED BY 668 MESH

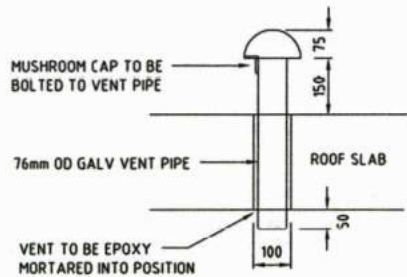

VENT MUSHROOM DETAIL (PROVISIONAL)

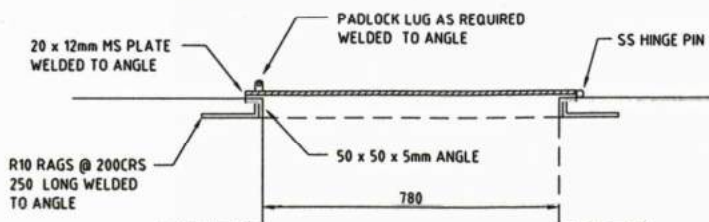

TYPICAL SECTION OF FLYGT COVER

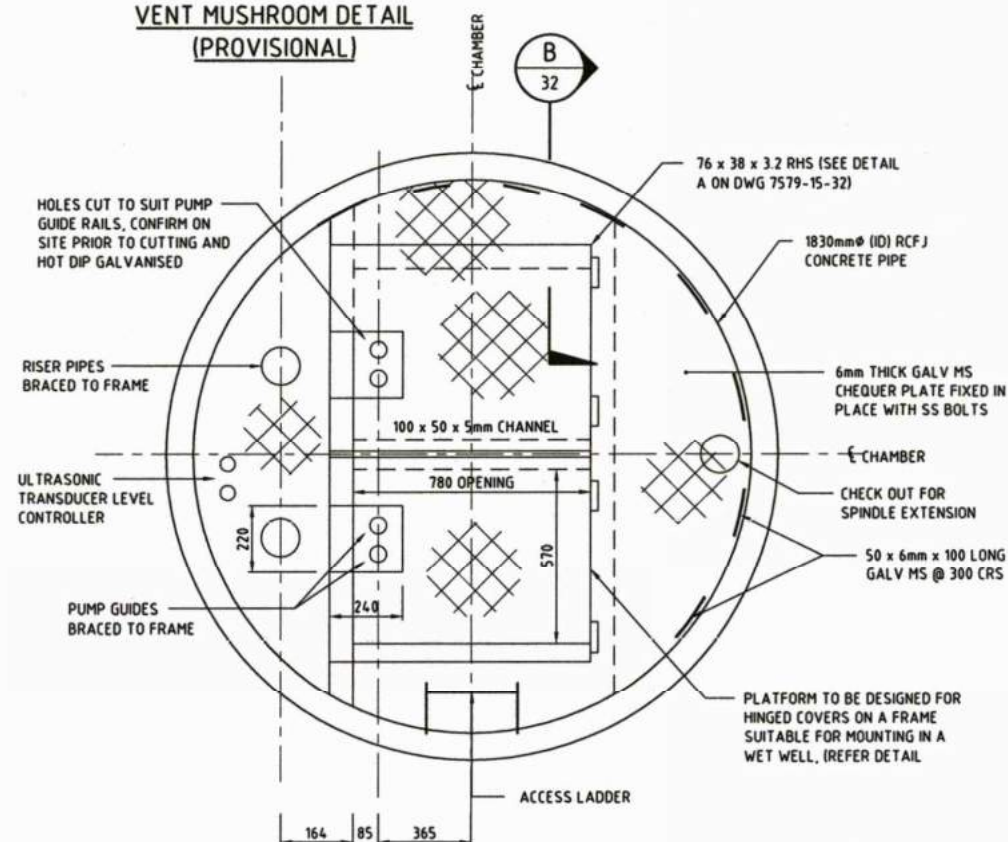

TYPICAL LAYOUT FOR MAINTENANCE PLATFORM

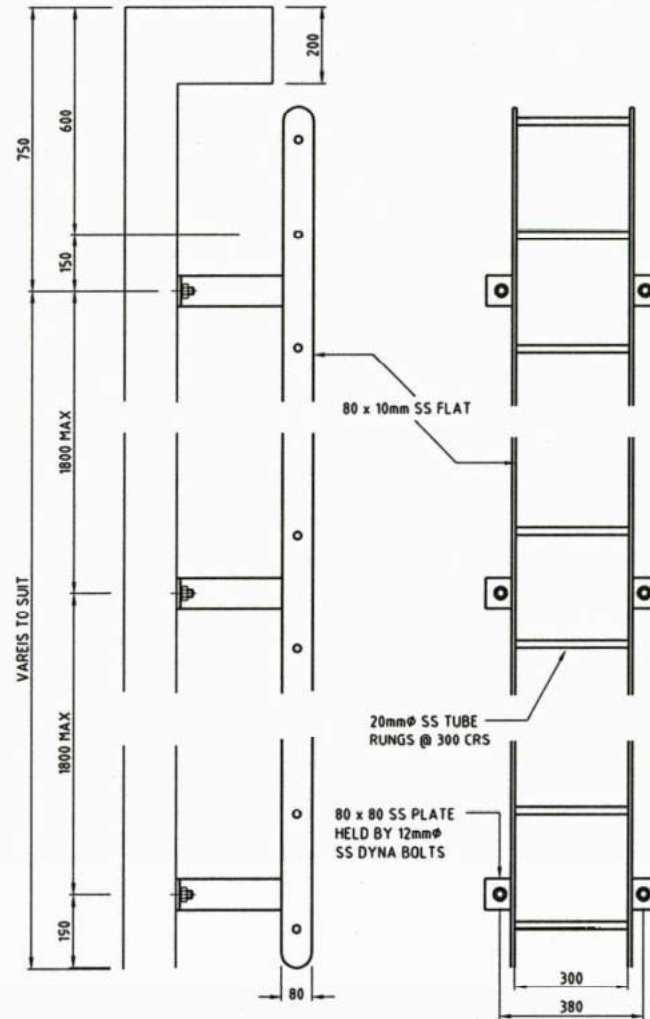

LADDER DETAIL

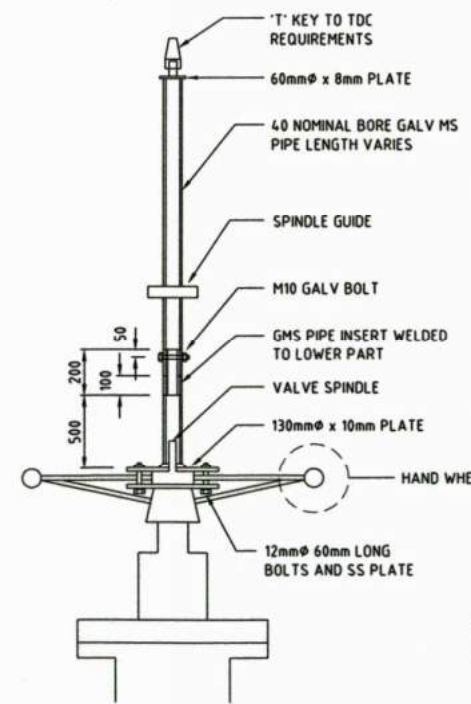

KNIFE VALVE EXTENSION SPINDLE

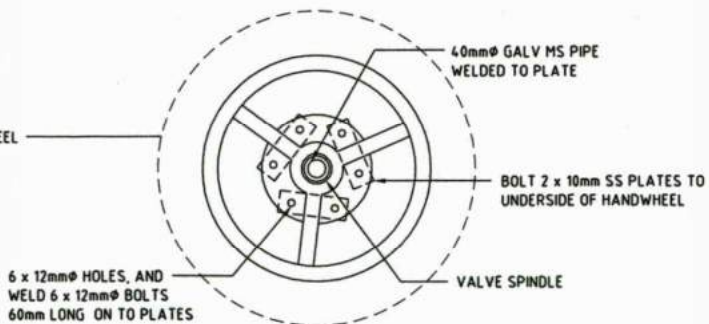

HANDWHEEL DETAIL

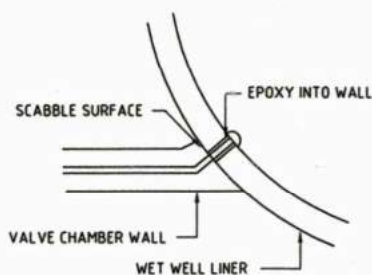

DETAIL A

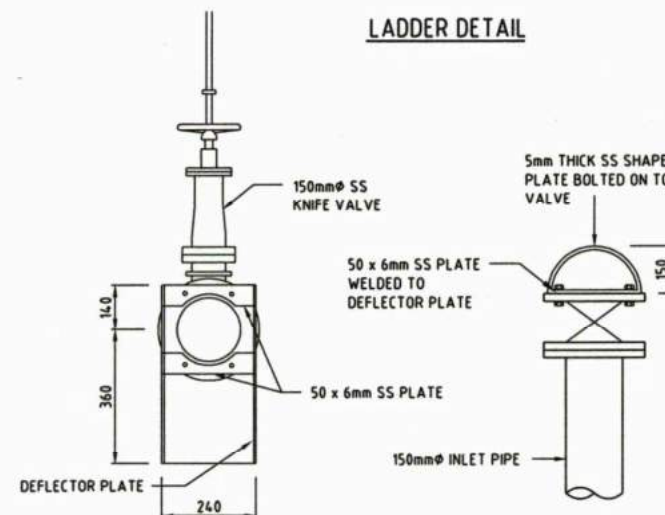

DEFLECTOR PLATE DETAIL

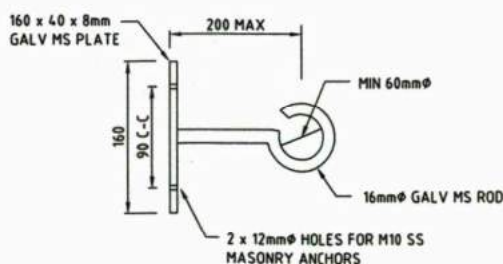

SPINDLE GUIDE

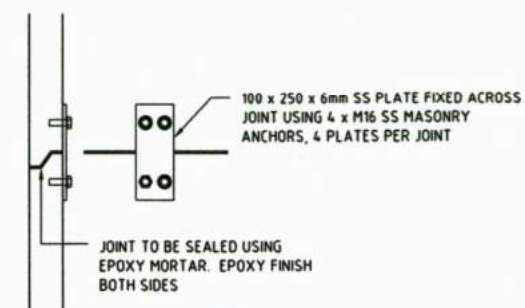

DETAIL B

Rev	Date	Revision Details	By	Ver	App
B	06.09.02	MINOR AMENDMENTS			CF
A	12.06.02	CONSTRUCTION ISSUE			CF
03	19.04.02	TENDER ISSUE			CF
02	8/4/02	AMENDMENTS MADE			JJF
01	2/4/02	PRELIMINARY ISSUE			JJF

Connell Wagner

Connell Wagner Ltd
143 Durham Street (PO Box 2292)
Tauranga, New Zealand
Telephone: +64 7 578 6183
Facsimile: +64 7 578 6143
Email: TGAcad@connwag.com

A person using Connell Wagner drawings and other data accepts the risk of:
1. using the drawings and other data in electronic form without requesting and checking them for accuracy against the original hard copy versions.
2. using the drawings or other data for any purpose not agreed to in writing by Connell Wagner.

Client:
LISLAND PROPERTIES LTD

Project:
**HOLY OAKS STAGE 2B
RESIDENTIAL SUBDIVISION
KINLOCH**

Drawing Title:
**SANITARY SEWER
PUMPSTATION DETAILS
(SHEET 1 OF 2)**

Drawn	Signed	Date	Verified	Signed	Date
JJF			NR		
Designed	Signed	Date	Approved	Signed	Date
NR			AL		

CW Project No.	7579-15	Scale:	NOT TO SCALE
Drawing No.	31	Revision:	B

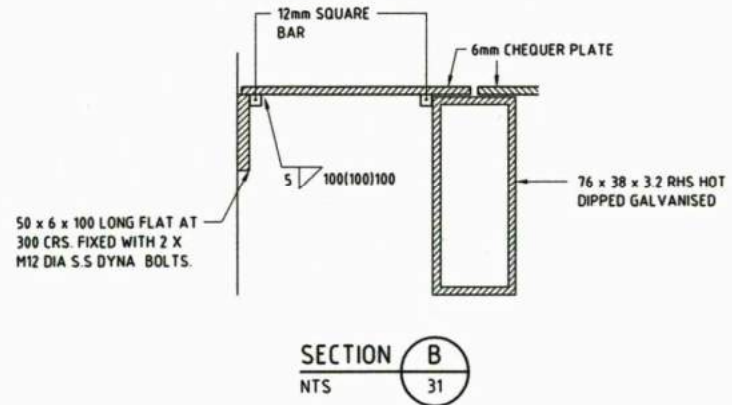
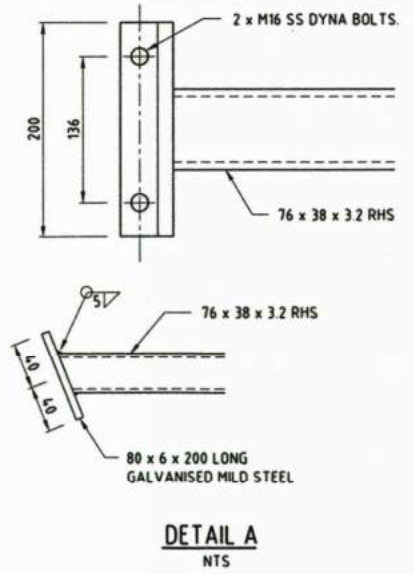
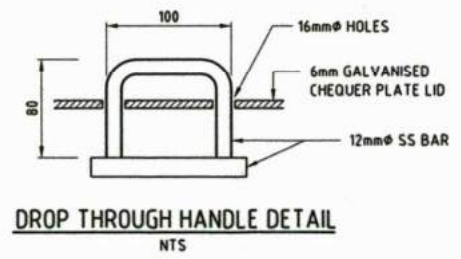
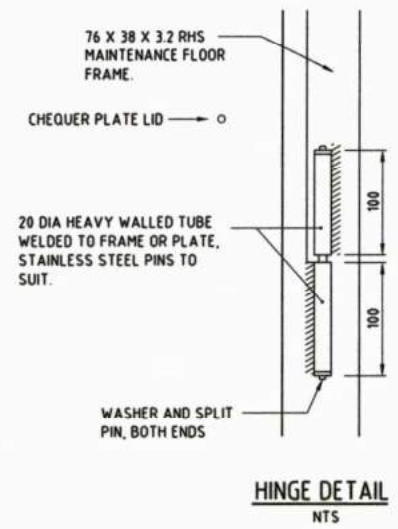
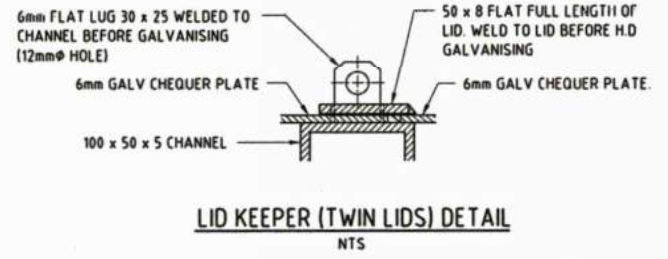
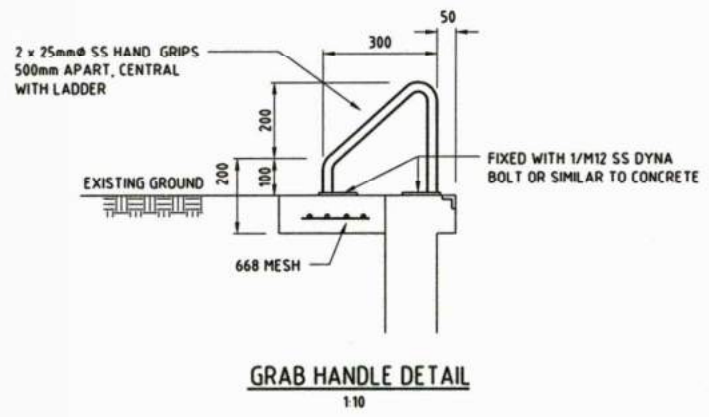
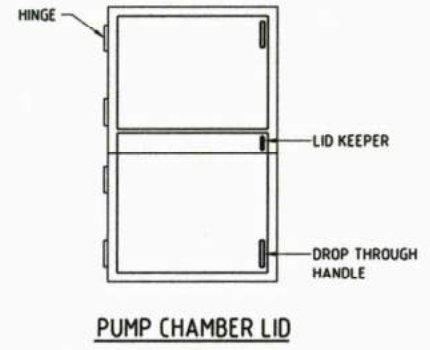
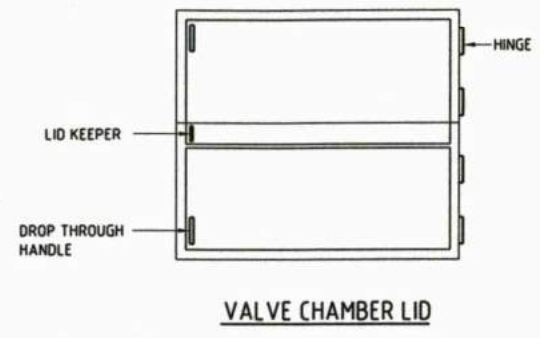
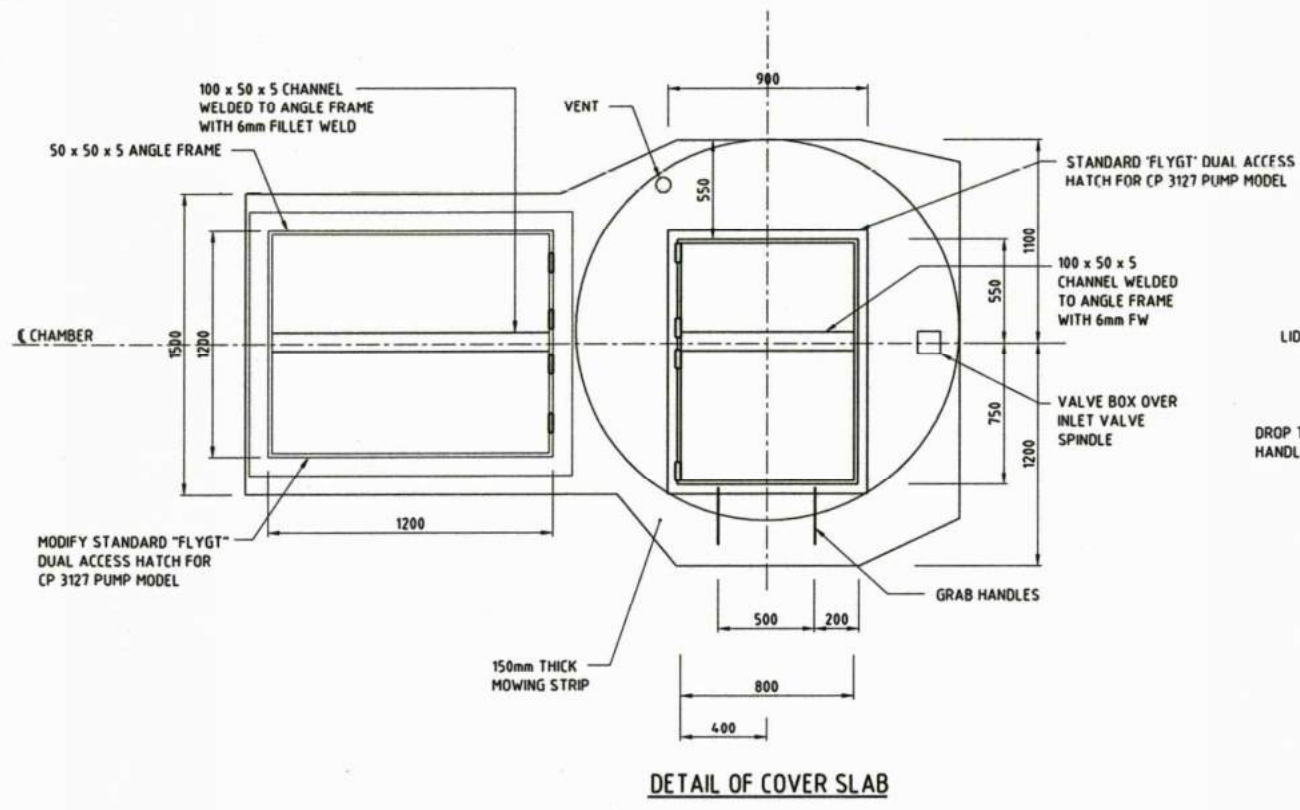

Rev	Date	Revision Details	By	Ver.	App.
B	06.09.02	AMENDMENTS TO CHAMBER	CF		
A	12.06.02	CONSTRUCTION ISSUE	CF		
03	19.04.02	TENDER ISSUE	CF		
02	8/4/02	AMENDMENTS MADE	JJF		
01	2/4/02	PRELIMINARY ISSUE	JJF		

Connell Wagner
 Connell Wagner Ltd
 143 Durham Street (PO Box 2292)
 Tauranga, New Zealand
 Telephone: +64 7 578 6183
 Facsimile: +64 7 578 6143
 Email: TGAcco@connwag.com

A person using Connell Wagner drawings and other data accepts the risk of:
 1. using the drawings and other data in electronic form without requesting and checking them for accuracy against the original hard copy versions.
 2. using the drawings or other data for any purpose not agreed to in writing by Connell Wagner.

Client:
LISLAND PROPERTIES LTD

Project:
**HOLY OAKS STAGE 2B
 RESIDENTIAL SUBDIVISION
 KINLOCH**

Drawing Title:
**SANITARY SEWER
 PUMPSTATION DETAILS
 (SHEET 2 OF 2)**

Drawn	Signed	Date	Verified	Signed	Date
JJF			NR		
Designed	Signed	Date	Approved	Signed	Date
NR			AL		
CW Project No		7579-15		Scale: AS SHOWN @ A1	
Drawing No		32		Revision: B	

CONSTRUCTION

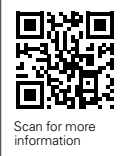

Hynds Retention Tank with Mul-T-Level™ Outlet

Technical Guide SW 22

Hynds strong and reliable retention tanks are available in Ring Joint Pipe or Flange Base Manholes.



06.18 | STORMWATER | SW22 HYNDS RETENTION TANK

Applications

Stormwater retention & detention
Sewer storage

Product Attributes

Versatile Mul-T-Level™ outlet
Highly durable
Simple installation
Various design layouts and large capacity options available
Water tight
Proven history

Approvals/Standards

AS/NZS 4058:2007 Precast concrete pipes (pressure and non-pressure)

Quality

ISO 9001:2008 Quality Management

The go to organisation for stormwater, industrial waste, and wastewater engineered systems



Hynds strong and reliable retention tanks are available in Ring Joint Pipe or Flange Base Manholes.

Design Specifications and Applications

RJ Retention Tank

- Generally used when the location permits the installation of a long narrow tank.
- Comprised of Hyspec steel reinforced concrete rubber ring joint pipes.
- Usually includes a spigot-plugged pipe, standard intermediate pipes and a collar-plugged pipe.
- The spigot and collar plugs are factory cast to ensure water tightness and integrity.
- A manhole offtake is factory fitted to one or more pipes to provide easy access for maintenance.

FB Retention Tank

- Generally used in compact site conditions where relatively small volumes is required.
- Comprised of Hynds or flange base manhole risers and a precast concrete lid.

Mul-T-Level™ outlet

- Enables the tank to be used for both detention and retention.
- Both the RJ and FB retention tanks have a standard 100 or 150mm diameter PVC slip coupler and Mul-T-Level™ outlet cast-in or fitted during manufacturing.
- The required retention/detention volume is set by an orifice hole (of specified diameter) being drilled on the Mul-T-Level™ outlet at a pre-determined height.

General Specifications

- Manufactured from Hyspec spun concrete pipes, using the centrifugal spinning process.
- When the tank is installed in an aggressive environment, such as tidal areas, sewerage or mild acid solutions, the use of a special grade concrete is recommended. Contact Hynds Technical Team for more information.
- Retention tanks are available in various class types to suit specific site conditions, loading and applications.
- The diameter and length of the retention tank is dependent on:
 - Storage volume required
 - Site configuration and access equipment available
- Inspection and maintenance access is provided by a fitted inspection chamber or manhole riser starter.
- PVC slip couplers are fitted to end plugs to provide inlet and outlet connections to the retention tank.
- Non-standard couplers or starter types can be cast-in on request.
- Orifice holes are drilled at levels to suit the design requirements.
- Standard lids are available for access risers in the RJ type tanks.
- A light or heavy duty cast iron cover and frame will fit directly onto the 600mm diameter access riser.
- The 1050 mm diameter access riser requires a 1050 mm diameter manhole lid, which can be fitted with the cast iron manhole frame and cover.
- The FB tanks require a lid, which can be fitted with a cast iron frame and cover to suit the riser diameter.
 - Note: Lid thickness is dependent on loads and application
 - Refer to Table 1 for RJ tank capacities and Tables 2 for FB tank capacities.

TABLE 1 RJ type retention tank

Nom Pipe Diameter and Joint Type	Pipe Effective Length (m)	Nom Vol per Pipe Length (m ³)	Nom Vol per Pipe Length (Litres)	Suggested Offtake Dia (mm)	Lifting plugged pipe anchor req.	Handling intermediate pipe anchor req.
675RJ	2.440	0.72	720	600	A1	A2
750RJ	2.440	0.92	920	600	A1	A2
825RJ	2.436	1.14	1140	600	A1	A2
900RJ	2.448	1.38	1380	600	A1	A2
975RJ	2.440	1.67	1670	600	B1	B2
1050RJ	2.440	1.94	1940	600	B1	B2
1200RJ	2.440	2.58	2580	600	B1	B2
1350RJ	2.454	3.31	3310	600/1050	B1	B2
1600RJ	2.440	4.51	4510	1050	C1	B2*
1800RJ	2.438	6.13	6130	1050	C1	C2
1950SRJ	2.440	7.05	7050	1050	C1	C2
2100SRJ	2.397	8.02	8020	1050	C1	C2
2300SRJ	2.735	11.01	11010	1050	C1	C2
2550SRJ	2.470	12.18	12180	1050	C1	C2

Key

- **A1** 1 Tonne
2 no. in plug
1 no. in pipe
- **A2** 1 Tonne
2 no. in pipe
- **B1** 2.5 Tonne
2 no. in plug
1 no. in pipe
- **B2** 2.5 Tonne
2 no. in pipe
- **C1** 5 Tonne
2 no. in plug
1 no. in pipe
- **C2** 5 Tonne
1 no. in pipe

Notes:

- All dimensions refer to Class 2 (X) pipes
- Outlet 75 mm minimum above bottom invert of pipe
- Overflow 125mm below top
- *1600 Ø retention tanks require both B2 & C1 type lifting clutches for offloading and installation
- See Fig 6 for 3 point lift on typical plugged end pipe

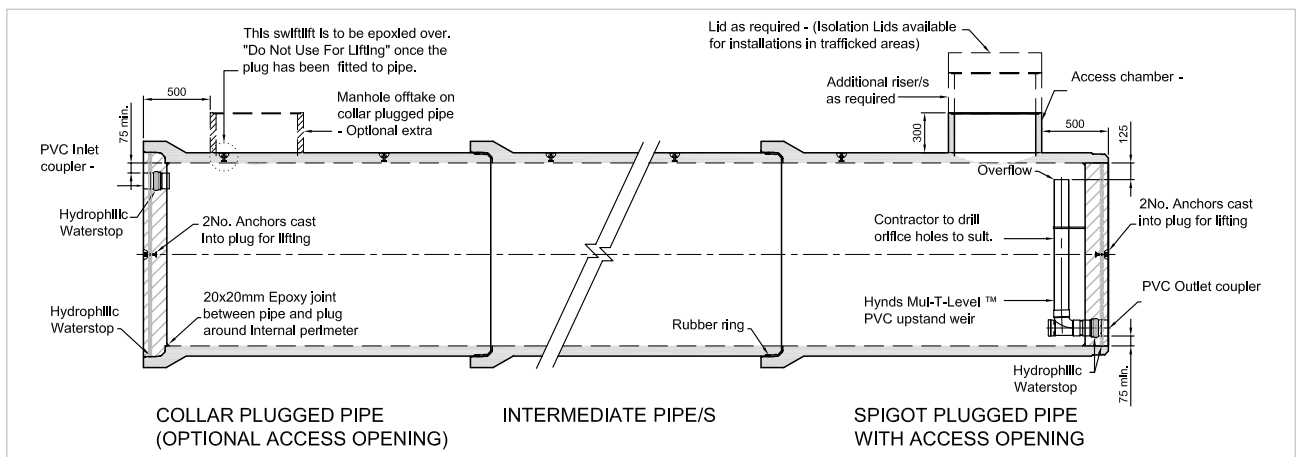

FIG. 1 General layout of typical RJ type retention tank with Mul-T-Level™ outlet

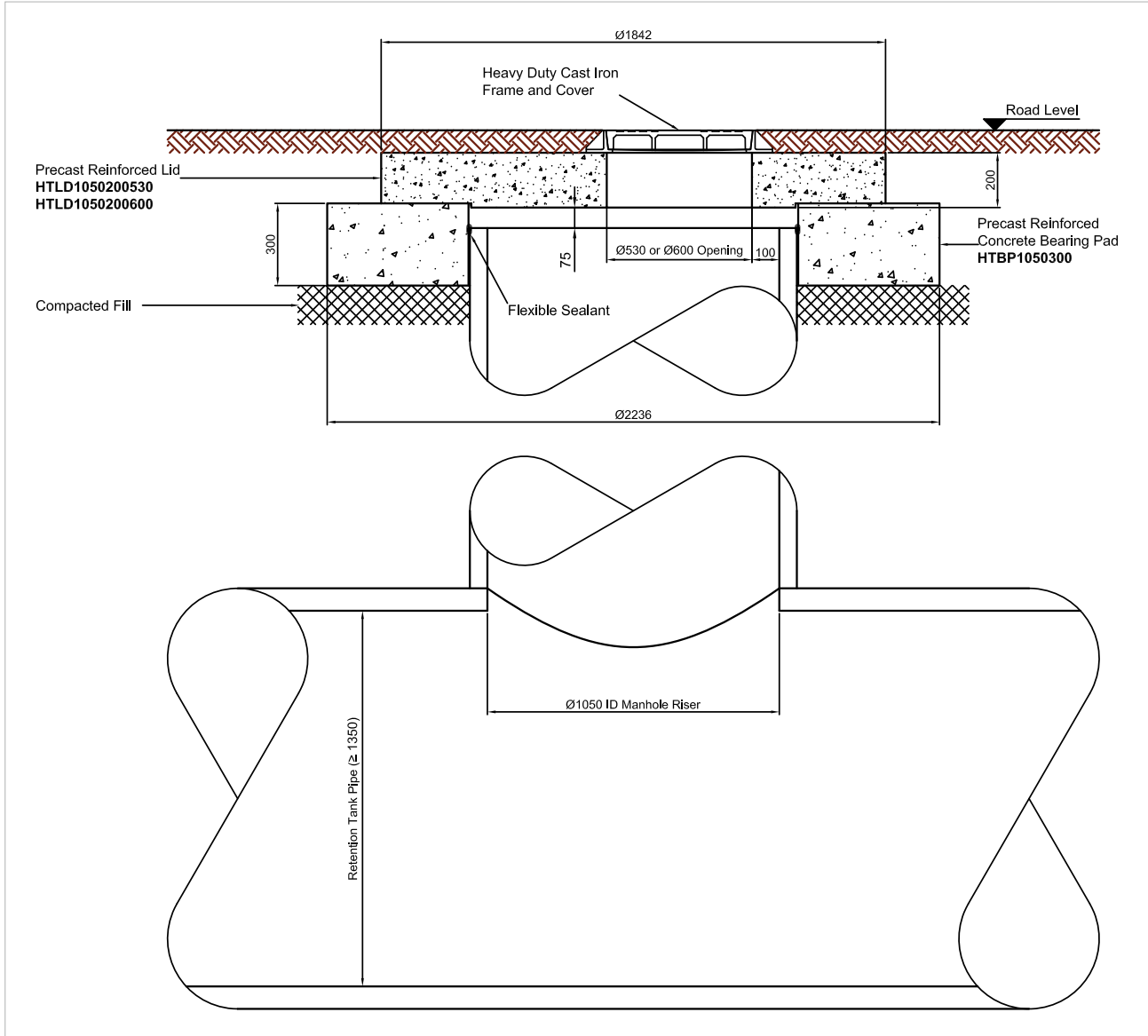

FIG. 2 Recommended detail for roadway installation

This swifit is to be epoxied over, "Do Not Use For Lifting" once the plug has been fitted to pipe.

Lid as required - (Isolation Lids available for installations in trafficked areas)

Manhole offtake on collar plugged pipe - Optional extra (Fill in box below if required)

Access chamber - (Fill in box below)

Additional riser/s as required

Overflow

Contractor to drill orifice holes to suit.

Hynds Mul-T-Level™ PVC upstand weir

Rubber ring

HYDROTITECJ2007 Hydrophilic Waterstop

2No. Anchors cast into plug for lifting

PVC Outlet coupler - (Fill in box below)

75 min.

500

300

500

125

20x20mm Epoxy joint between pipe and plug around internal perimeter

HYDROTITECJ2007 Hydrophilic Waterstop

2No. Anchors cast into plug for lifting

PVC Inlet coupler - (Fill in box below)

75 min.

500

COLLAR PLUGGED PIPE (OPTIONAL ACCESS OPENING)

INTERMEDIATE PIPE/S

SPIGOT PLUGGED PIPE WITH ACCESS OPENING

PIPE Ø
Mn Recommended Ø 675mm

PIPE CLASS

TOTAL No. OF PIPES (Incl. ends)

COVER TO INVERT

Inlet	Outlet
<input type="text"/>	<input type="text"/>

PVC INLET FITTING Ø

Pipe Ø	Standard Fitting Ø	Ø Required
Ø675 to 1200mm	Ø100mm	<input type="text"/>
Ø1350 to 3000mm	Ø150mm	

PVC OUTLET FITTING Ø

Ø Pipe	Standard Fitting Ø	Ø Required
Ø675 to 1200mm	Ø100mm	<input type="text"/>
Ø1350 to 3000mm	Ø150mm	

ACCESS CHAMBER - OUTLET SIDE Ø

Ø Pipe	Standard Offtake Ø	Ø Required
Ø675 to 1200mm	Ø600mm	<input type="text"/>
Ø1350 to 3000mm	Ø1050mm	
Ø1350 to 3000mm	Specify	

ACCESS CHAMBER - OPTIONAL INLET SIDE Ø

Ø Pipe	Standard Offtake Ø	Ø Required
Ø675 to 1200mm	Ø600mm	<input type="text"/>
Ø1350 to 3000mm	Ø1050mm	
Ø1350 to 3000mm	Specify	

JOB DETAILS

QUOTE No.

CO No.

I AUTHORISE HYNDS PIPE SYSTEMS LTD TO PROCEED WITH THE MANUFACTURING OF THIS PIPE SPECIAL AS DETAILED ABOVE. I ACKNOWLEDGE THAT ANY SPECIALS, ONCE MANUFACTURED, ARE DEEMED TO BE MY (CONTRACTOR'S) PROPERTY & ARE NON REFUNDABLE. STORAGE & HANDLING FEES WILL BE INCURRED FOR PRODUCTS THAT ARE NOT DELIVERED/COLLECTED WITHIN 1 MONTH OF THE DATE AGREED AT THE TIME OF ORDER. PRODUCT NOT DELIVERED/COLLECTED WITHIN 3 MONTHS OF THE DATE AGREED WILL BE DESTROYED AT MY EXPENSE.

NAME :- SIGNATURE :-

DATE :-

FIG. 3 RJ Retention Tank Order Form

Flange base type

TABLE 2 Flange base retention tank

Riser Height (mm)			450	600	900	1200	1500	1800	2100	2400
O/A Height Incl 150mm Thick Lid			530	680	980	1280	1580	1880	2180	2480
O/A Height Incl 200mm Thick Lid			580	730	1030	1330	1630	1930	2230	2530
Effective Depth (mm)			225	375	675	975	1275	1575	1875	2175
Nominal Diameter	A = Riser OD (m)	B = Riser ID (m)	FB Capacity (m ³)							
1050	1.194	1.066	0.20	0.33	0.60	0.87	1.14	1.41	1.67	1.94
1200	1.347	1.207	0.26	0.43	0.77	1.12	1.46	1.80	2.15	2.49
1400	1.524	1.372	0.33	0.55	1.00	1.44	1.88	2.33	2.77	3.22
1500	1.677	1.523	0.41	0.68	1.23	1.78	2.32	2.87	3.42	3.96
1650	1.842	1.676	0.50	0.83	1.49	2.15	2.81	3.47	4.14	4.80
1800	2.007	1.829	0.59	0.99	1.77	2.56	3.35	4.14	4.93	5.71
2050	2.236	2.036	0.73	1.22	2.20	3.17	4.15	5.13	6.10	7.08
Effective Depth (mm)			-	-	625	925	1225	-	-	2125
Nominal Diameter	A = Riser OD (m)	B = Riser ID (m)	FB Capacity (m ³)							
2300	2.58	2.30	-	-	-	3.84	-	-	-	8.83
2550	2.85	2.55	-	-	3.19	-	6.26	-	-	10.85

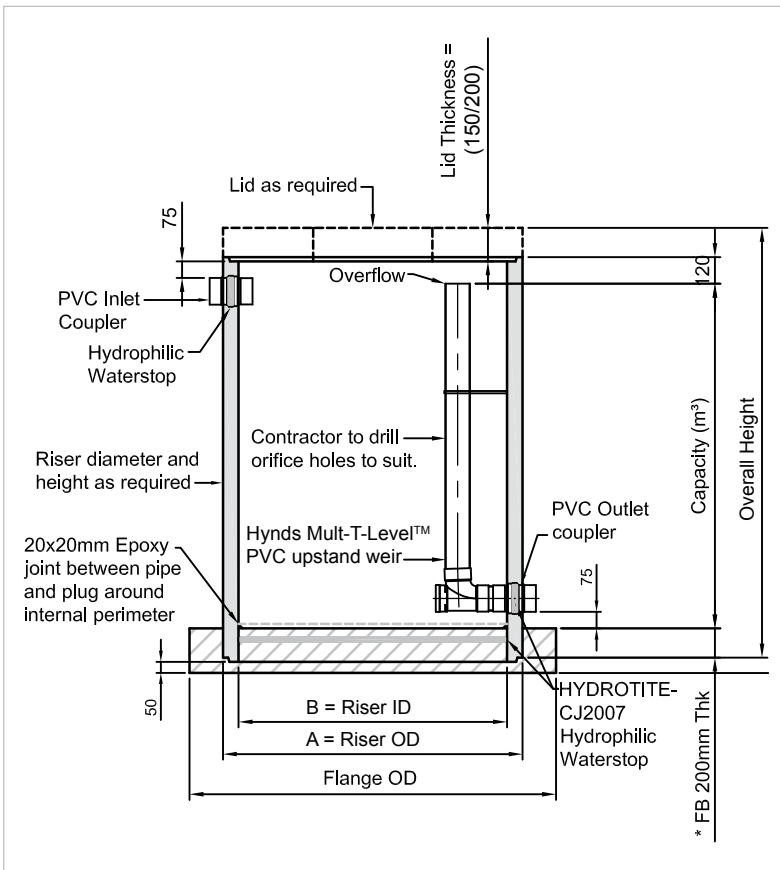

FIG. 4 Flange base

Installation

Mul-T-Level™ outlet

- Installation is simple and normally carried out by a drain layer using the same equipment and procedures as for the installation of concrete pipelines, or manholes.

RJ Retention Tank

- Similar installation to reinforced concrete rubber ring jointed pipes (including bedding requirements) and are dependent on site conditions and loading.
- Once the pipe sections have been installed and backfilled, the additional access risers are epoxied to the starter risers and brought up to the finished levels.
- The installation is then completed by fitting the required lids.
- The contractor must then drill the orifice holes at the required design levels.

Note: Refer to Figure 1 for a general layout of a typical RJ type tank.

RJ Retention Tank – Roadway Installation

- To minimise the effects of traffic, isolation of the manhole lid from the access riser is recommended.
- The depth of the modified flange base and riser must be kept to a minimum to enable maximum distribution of load above the tank.
- Refer to Figure 5 for 3 point lift of typical plugged end pipe.

FB Retention Tank

- Similar installation to concrete manholes.
- Foundations should be prepared with compacted hardfill to prevent excessive settlement.
- Once the FB tank is backfilled, the installation is completed by fitting the relevant concrete lid with the appropriate cast iron frame.



FIG. 5 Point lift of typical plugged and pipe

Appendix 4

Taupō District Council
Kinloch Future Development
Map

Te Tuhi
 44 Lots Restricted Flow Residential Demand
 Timing: Developed now, but connection likely all by 2035 (after The Terraces)
WSP to import scheme plan provided and prepare concept to supply lots above Kinloch High Zone.

Top end of Kinloch High Pressure Zone (480m Elevation contour)

Hunt Club Inc.
 30 Lots Full Residential Demand
 Timing: 2030-2035
No Scheme plan provided, connection assumed

The Terraces
 55 Lots Full Residential Demand, connected to High Zone
 Timing: 2025-2035
Scheme plan provided, recommendations for pipe size will be provided.

Oakdale Downs
 Total 82 Lots Full Residential Demand,
 Timing: Development completed 2019,
 All lots connected by 2025
Refer to latest GIS for customer points

Seven Oaks,
 Stage 1-9,
 160 Lots Full Residential Demand,
 Balance Lot (Stage 10) 30 Lots Full Residential Demand
 Stage 1 to 7 connected to Low Zone
 Stage 8,9 and Balance Lot to High Zone
 Timing: 2020-2026
Scheme plan provided, recommendations for pipe size already provided in development enquiry.

Oakdale Drive,
 12 Lots Full Residential Demand,
 Timing: 2025-2030

Kinloch Fill In lots (including the Poplars, Locheagles and Fairways) Township
 96 Lots Full Residential Demand,
 Timing: 2020-2035

Workshop Site
 6 Lots Full Residential Demand
 Timing: 2025

Poplars Stage 2
 12 Lots Full Residential Demand
 Timing: 2020-2025

Whangamata Private supply scheme
 Potential to connect private scheme to the Kinloch Water Supply Network in the future. Currently approx. 70 Lots Farm Demand WSP will check the impact of the connection on the 2050 model. Separate assessment required to determine operational impact (additional PS, reservoir etc?)

The Fairways
 54 Lots Full Residential Demand
 Timing: 2020-2040
 Currently already some lots connected, balance to be connected by 2040

Kinloch Golf Course / Low Density Zone
 108 Lots Full Residential Demand
 Timing: 2035-2050

The Kinloch Manor
 12 Lots Full Residential Demand
 Timing 2025-2030

New Water Treatment Plant Site

Edmund Hillary Outdoor Education
 1 Lot Restricted Residential Demand
 Timing: 2025

Locheagle Developments
 as per Sheet 1 Kinloch Fill in Lots.

Nu further development in the Whakarao DMA

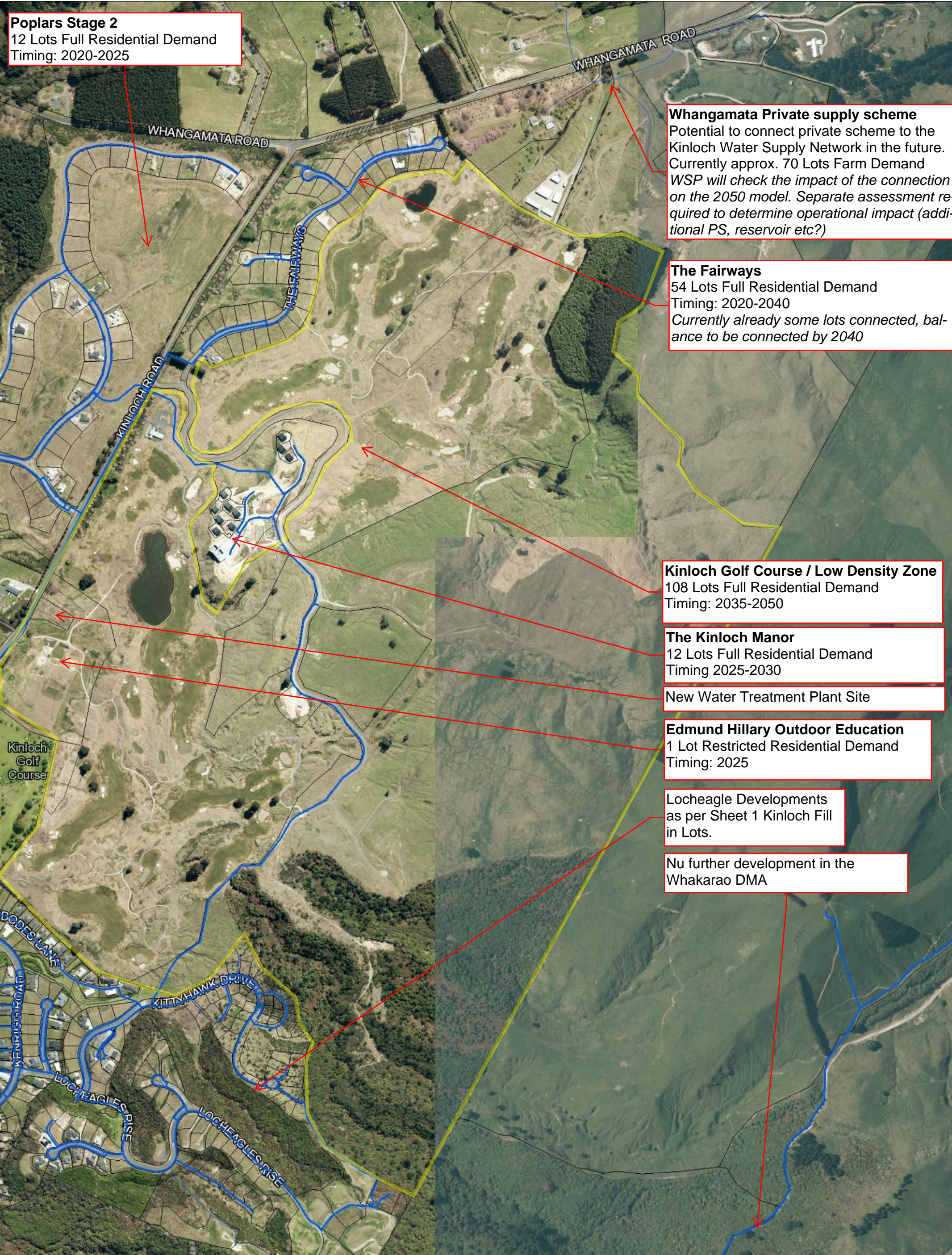

Appendix 5

Upper Catchments and
Preliminary Swale Sizing

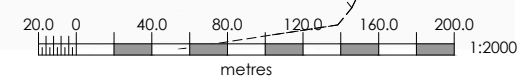
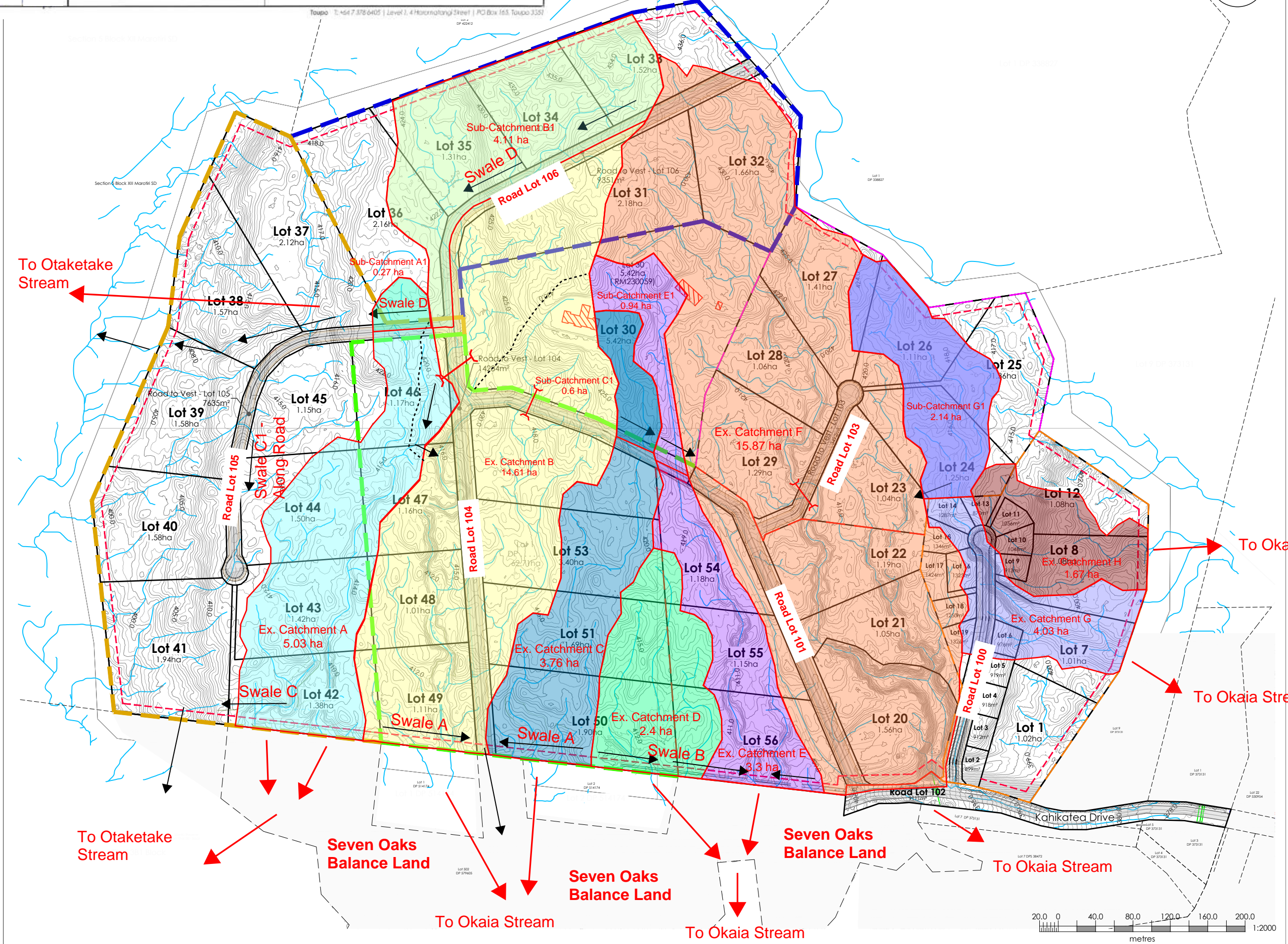

C_exist= 0.2 E1/VM1 pasture, high soakage
 i_10 = 21.7 Rainfall (mm), 10 year, 30 min.
 i_100 = 35.3 Rainfall (mm), 100 year, 30 min.

Catchment Name	Size (m2)	10 Year Flows (existing) m3/s	100 Year Flows (existing) m3/s
A	90000	0.65	1.06
B	66000	0.48	0.78

High soakage gravel, sandy and volcanic soil types:
 - pasture and grass cover 0.20
 - bush and scrub cover 0.15
 - cultivated 0.10

Swale Sizing for Catchment B

100 year event, existing

	Swale B
Peak Flow (m3/s)	0.78
Base Width (m)	1.5
Side Slopes (1v:Xh)	4
Water Depth (m)	0.25
Freeboard (m)	0.5
Top Width (m)	7.5
Top Width of Flow (m)	3.5
Slope (m/m)	1.5%
Mannings Roughness, n	0.03
Area (m2)	0.625
Hydraulic Radius (m)	0.18
Velocity (m/s)	1.280
Channel Flow (m3/s)	0.80
Pass/Fail	PASS

C_future 0.25 Calculated Below
 i_10 = 29.1 Rainfall (mm), 10 year, 30 min.
 i_100 = 48.1 Rainfall (mm), 100 year, 30 min.

Catchment Name	Size (m2)	10 Year Flows (future) m3/s	100 Year Flows (future) m3/s
B/C	183700	2.24	3.70
D/E	57000	0.69	1.15

For C_future, assuming 300m2 roof, 400m2 hard stand per lot, and 400m2 of road per lot. Average 1.5ha lots.

C_grass = 0.2
 C_hard = 0.9
 A_grass = 13900 m2
 A_hard = 1100 m2
 C_future = 0.25

Swale Sizing for Catchment D/E

100 year event, Future

	Swale D/E
Peak Flow (m3/s)	1.15
Base Width (m)	2
Side Slopes (1v:Xh)	6
Water Depth (m)	0.3
Freeboard (m)	0.5
Top Width (m)	11.6
Top Width of Flow (m)	5.6
Slope (m/m)	1.5%
Mannings Roughness, n	0.03
Area (m2)	1.14
Hydraulic Radius (m)	0.20
Velocity (m/s)	1.404
Channel Flow (m3/s)	1.60
Pass/Fail	PASS

Culvert Sizing, Swale D/E

100 year event, pipe full

	Culvert D/E
Peak Flow (m3/s)	1.15
Pipe Diameter (mm)	750
Slope (m/m)	2.0%
Mannings Roughness, n	0.013
Hydraulic Radius (mm)	187.5
Area (m2)	0.44
Velocity (m/s)	3.564
Channel Flow (m3/s)	1.57
Pass/Fail	PASS

Appendix 6

Catchments included in
Stage 2 Stormwater Pond

PROPOSED STORMWATER SOLUTION

cheal

www.cheal.co.nz

NOTES:

This plan has been prepared for the purpose of a resource consent application only. It is not a precise survey plan. As areas and dimensions are likely to vary upon survey it should not be attached to any sale & purchase agreements without an appropriate condition to cover such variations.

Owner: Seven Oaks Kinloch Ltd

Record of Title: Balance of Stage 1 subdivision (not yet issued)
Total Area: 34.60 ha

Refractured services will require additional easements after final construction and development of the legal survey.

Rights of way to rear Lots are a minimum 4m wide.

LEGEND:

- Proposed Boundaries
- Existing Boundaries
- Easement
- ROW
- LP Reserve to vest (Stormwater)
- LP Reserve to vest (Stormwater & Recreation)
- Recreation Reserve to vest
- Stormwater Pond
- Proposed Road
- Proposed Swale Drain
- Balance Lot Boundary
- 3m Setback
- 5m Setback
- 7.5m Setback
- Footpath - 1.4m Wide
- Cycleway - 1.8m Wide
- Combined Footpath & Cycleway
- Bush Walkway-Cycleway
- Existing K&K Track
- Pool Fence

SEVEN OAKS

Rev	Date	Amendment	By	IC/KA/APP
E	14/03/20	Stage 5 & 9 Layouts Amended Footpaths, Cycleways and Pool Fence shown	PS	PSH SGP
D	21/01/20	Stages 3 & 8 1st Resource Consent Amended	PS	PSH SGP

Project Title
Seven Oaks Kinloch Ltd.
Okai Drive
Kinloch

Drawing Title
Scheme Plan
Stages 2 to 9
Sheet 1 of 3

Task	By	Date
Surveyed		
Designed	P. Ray	14/11/19
Drawn	P. Ray	14/11/19
Checked	S. Forth	14/11/19
Approved	S. Forth	14/11/19

Status: **RESOURCE CONSENT**

Scale: A1 | A3
A3 1:4000 | A3

Drawing Number: 19630-SC001 | Rev: E

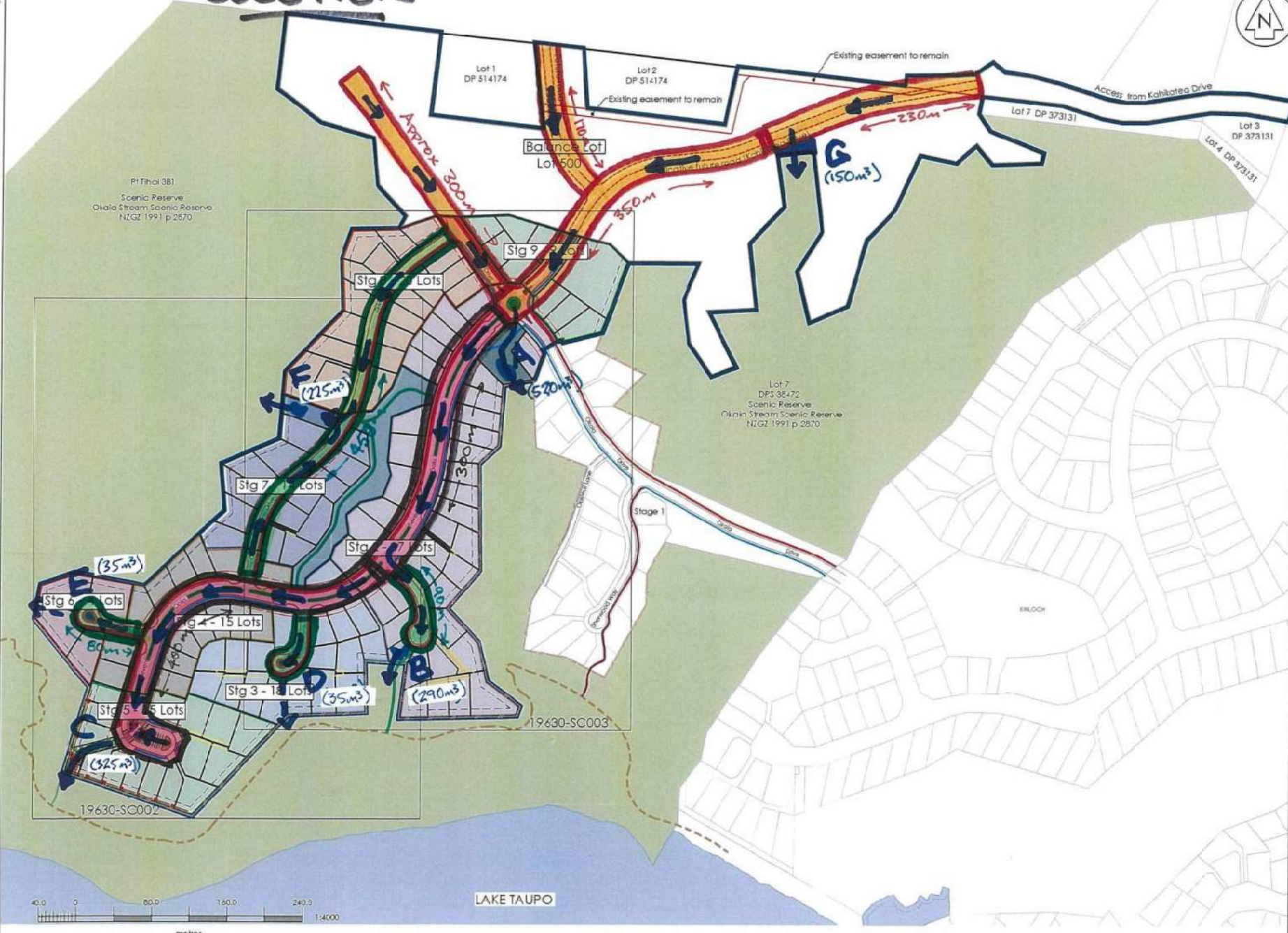

Pitihai 381
Scenic Reserve
Okai Stream Scenic Reserve
NZGZ 1991 p.2870

Lot 7
DP: 38472
Scenic Reserve
Okai Stream Scenic Reserve
NZGZ 1991 p.2870

LAKE TAUPO